

THE NEW VALUE FRONTIER



Grooving / Cut-Off | **KGD/KGDF**

Grooving / Cut-Off

KGD/KGDF

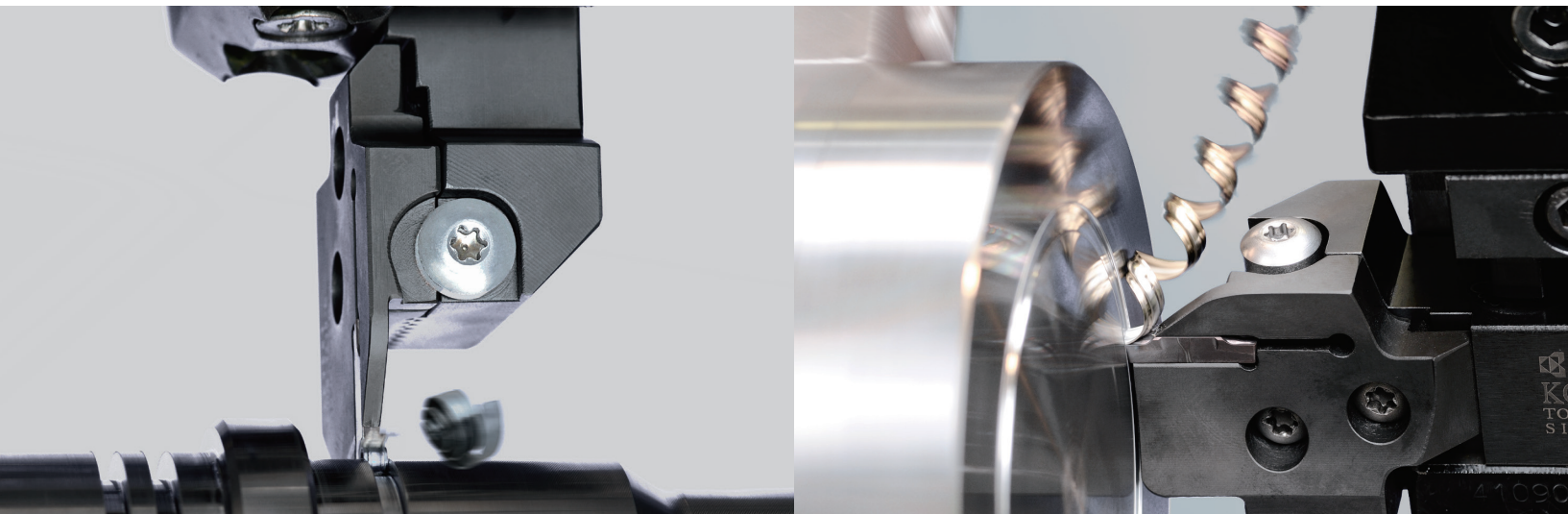

Improved Grooving Performance with Expansive Lineup of Chipbreakers and Toolholders

Good chip control

MEGACOAT coating technology for long tool life and high efficiency machining

Comprehensive Toolholder Lineup



KGD

Good chip control

MEGACOAT coating technology for long tool life and high efficiency machining

1 Wide Range of Chipbreakers

Application Maps

External Grooving and Traversing

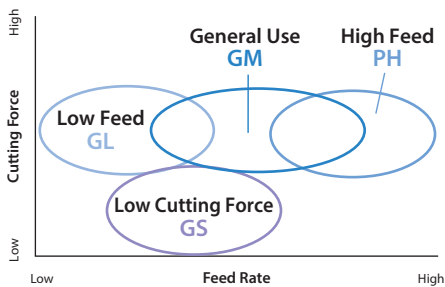

Cut-Off

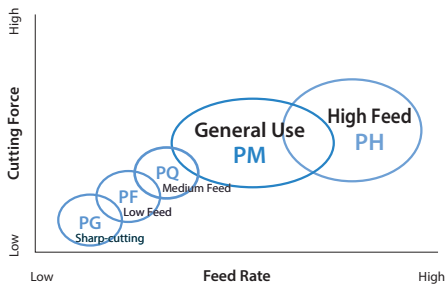

Chipbreaker Selection(External)

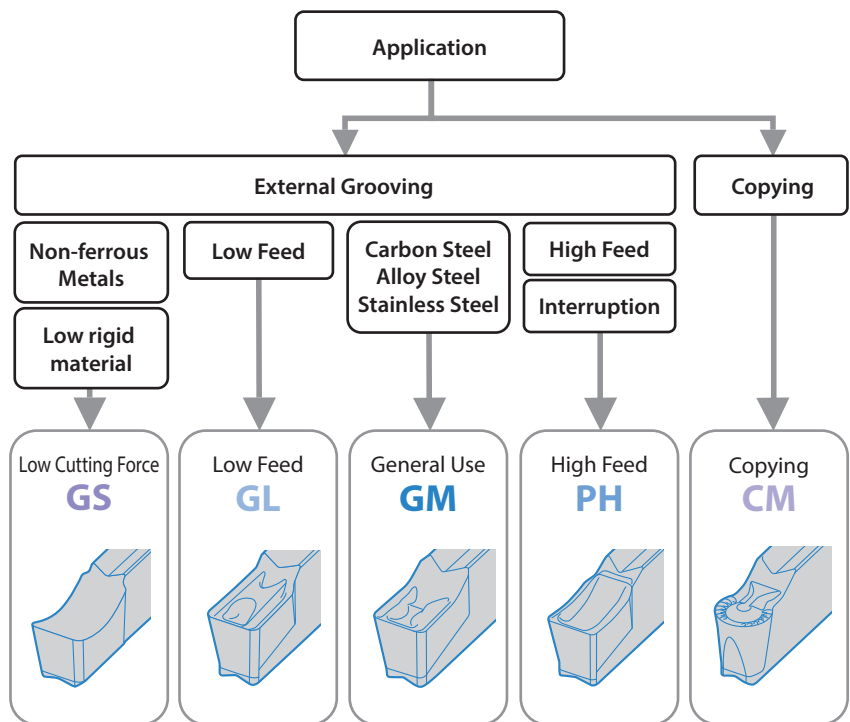

Comparison of Chip Control (In-house Evaluation)

Cutting Conditions : $V_c = 150$ m/min, $f = 0.15$ mm/rev Workpiece : SCM415

Better chip control than competitors

Reduces damage of cutting edge caused by crushing chips

GM Chipbreaker



Competitor A



Competitor B



2

MEGACOAT/MEGACOAT NANO coating technology for long tool life

Coating Properties

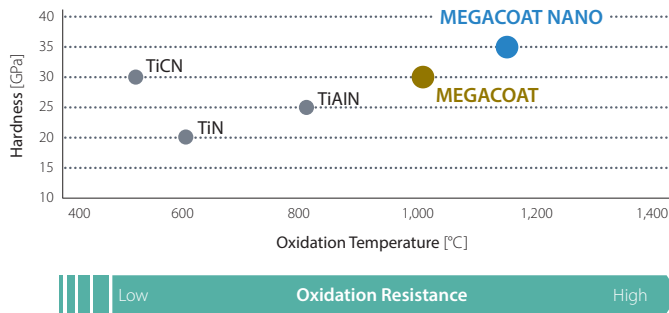

PR1225 (MEGACOAT)
For Steel Grooving and Cut-off

PR1215 (MEGACOAT)
Superior wear resistance
For machining of cast iron

PR1535 (MEGACOAT NANO)
For machining of stainless steel



3

Various Toolholder Lineup

Available two types of toolholder, Integral type and SwitchBlade type.

Integral Type



SwitchBlade Type



Integral type toolholder with wide lineup (for various groove width and depth)

SwitchBlade type toolholder : Applicable for various types of grooving and cut-off, such as external and face grooving by replacing blade parts.

Integral type / SwitchBlade type Selection Reference

Integral Type	SwitchBlade Type
<ul style="list-style-type: none"> • Various toolholder lineup Available for various groove depth (shallow / medium / deep) Optimum overhang length • Available for low-rigid machine and workpiece • For small machine with limited work space (Automatic lathe, small lathe, etc.) 	<ul style="list-style-type: none"> • Suitable for high-mix low-volume production Suitable for grooving with various width Applicable for various groove width by replacing blades • Suitable for difficult-to-cut material Tough cutting conditions Toolholder cost reduction (replaceable blade) • Face grooving is possible by changing blade <p>* Make sure right hand / left hand</p>

Face Grooving KGDF Toolholder and GDFM Inserts → P17



The new "W Grip" is applied for more rigid clamping and stable machining.

1. Prevent the insert from side-slip causing unstable machining and insert breakage.
2. Improved indexability accuracy.

High rigidity, reliability and clamping strength.

Insert for GDFM/GDFMS is not compatible with KGD toolholder.

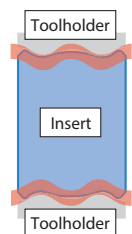

W Grip

GDM/GDMS/GDG (External Grooving and Traversing)

Applicable Inserts

Insert		Description	Dimensions(mm)					Cermet		MEGACOAT NANO		MEGACOAT		Carbide
			W	re	M	L	H	TN620	TN90	PR1535	PR1225	PR1215	GW15	
Grooving and Traversing	General Use	GDM 2420N-020GM	2.4	±0.03	0.2	1.95	20	4.3	●	○	●	●	●	●
		3020N-020GM	3.0		0.4	2.3			●	●	●	●	●	●
		3020N-040GM	3.0		0.4	3.3			●	●	●	●	●	●
		4020N-020GM	4.0	0.2	3.3	●			●	●	●	●	●	●
		4020N-040GM		0.4		3.3			●	●	●	●	●	●
		4020N-080GM		0.8		3.3			●	●	●	●	●	●
		5020N-040GM	5.0	0.4	4.2	●			●	●	●	●	●	●
		5020N-080GM		0.8		4.2			●	●	●	●	●	●
		6020N-040GM		0.4		5.2			●	●	●	●	●	●
	6020N-080GM	6.0	0.8	5.2	●	●	●	●	●	●				
	8030N-080GM	8.0	±0.05	0.8	6.0	30	5.5	●	●	●	●	●		
	General Use 1-edge	GDM 2420N-020GM	2.2	±0.03	0.2	1.75	20	4.3	●	●	●	●	●	●
		3020N-040GM	3.0		0.4	2.3			●	●	●	●	●	●
		4020N-040GM	4.0		0.4	3.3			●	●	●	●	●	●
		5020N-080GM	5.0	±0.04	0.8	4.2			●	●	●	●	●	●
6020N-080GM		6.0	0.8		5.2	●			●	●	●	●	●	
Low Feed	GDM 2420N-020GL	2.4	±0.03	0.2	1.95	20	4.3	●	●	●	●	●	●	
	3020N-020GL	3.0		0.4	2.3			●	●	●	●	●	●	
	3020N-040GL	3.0		0.4	3.3			●	●	●	●	●	●	
	4020N-020GL	4.0	0.2	3.3	●			●	●	●	●	●	●	
	4020N-040GL		0.4		3.3			●	●	●	●	●	●	
	5020N-040GL		0.4		4.2			●	●	●	●	●	●	
6020N-040GL	6.0	±0.04	0.4	5.2	●	●	●	●	●	●				
Grooving	Low Cutting Force	GDG 2520N-020GS	2.5	±0.02	0.2	2.0	20	4.3	●	●	●	●	●	●
		3020N-020GS	3.0		0.2	2.3			●	●	●	●	●	●
		3520N-020GS	3.5		0.2	2.8			●	●	●	●	●	●
		4020N-040GS	4.0		0.4	3.3			●	●	●	●	●	●
		5020N-040GS			0.4	4.2			●	●	●	●	●	●
		6020N-040GS			0.4	5.2			●	●	●	●	●	●
		8030N-040GS	8.0		±0.02	0.4			6.0	30	5.5	●	●	●
Full-R / Copying		GDM 3020N-150R-CM	3.0	±0.03	1.5	2.3	20	4.3	●	●	●	●	●	
		4020N-200R-CM	4.0		2.0	3.3			●	●	●	●	●	
		5020N-250R-CM	5.0	±0.04	2.5	4.2			●	●	●	●	●	
		6020N-300R-CM	6.0		3.0	5.2			●	●	●	●	●	
Grooving and Cut-Off (High Feed)	1-edge	GDM 2020N-020PH	2.0	±0.03	0.2	1.5	20	4.3	●	●	●	●	●	
		3020N-030PH	3.0		0.3	2.3			●	●	●	●	●	
		4020N-030PH	4.0		0.3	3.3			●	●	●	●	●	
	GDMS 2020N-020PH	2.0	±0.03	0.2	1.5	●			●	●	●	●		
	3020N-030PH	3.0		0.3	2.3	●			●	●	●	●		
4020N-030PH	4.0	0.3	3.3	●	●	●	●	●	●					

* GDM50/60-CM differs from other descriptions in length (L) to avoid interference of a toolholder with workpiece.

● : Standard Stock

*** KGD / KGM Combinations**

Insert Setting Angle of KGD / KGM Toolholders

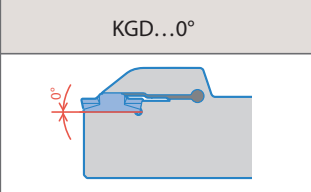
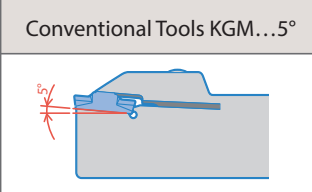
KGD...0°	Conventional Tools KGM...5°
	

New Insert GDM



⊙

New Toolholder KGD

Conventional Insert GMM

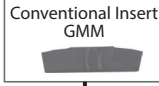

↓

Conventional Toolholder KGM





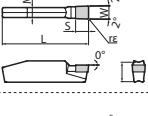

Not recommended to install conventional inserts on new toolholder.

GDGS(CBN / PCD) / GDM / GDG(Cut-Off)

Applicable Inserts

Insert	Description	Dimensions(mm)						Angle	MEGACOAT CBN	CBN	PCD		
		W	Tolerance	rε	M	L	H					S	θ
 1-edge	CBN 	GDGS 2020N-020NB	2.0	±0.03	0.2	1.8	20	4.3	2.9	—	●	●	●
		3020N-020NB	3.0	0.2	2.3	●					●	●	
	3020N-040NB	3.0	0.4	2.3	●	●					●		
	4020N-020NB	4.0	0.2	3.3	●	●					●		
	4020N-040NB	4.0	0.4	3.3	●	●					●		
	5020N-020NB	5.0	0.2	4.2	●	●					●		
	5020N-040NB	5.0	0.4	4.2	●	●					●		
	6020N-020NB	6.0	0.2	5.2	●	●					●		
	6020N-040NB	6.0	0.4	5.2	●	●					●		

● : Standard Stock

Insert	Description	Dimensions(mm)						Angle	MEGACOAT NANO	MEGACOAT			DLC Coated Carbide	Carbide	
		W	Tolerance	rε	M	L	H			θ	PR1535	PR1225			PR1215
 Cut-Off (Low Feed)	GDM 1316N-003PF 1316N-015PF 1516N-003PF 1516N-015PF 2020N-003PF 2020N-015PF 2520N-003PF 2520N-015PF 3020N-003PF 3020N-015PF	1.3	±0.04	0.03	1.0	16	3.7	—	●	●	●				
		1.5	0.03	1.2	●				●	●					
		2.0	0.03	1.7	●				●	●					
		2.5	0.15	2.1	●				●	●					
		3.0	0.15	2.3	●				●	●					
		3.0	0.15	2.3	●				●	●					
	 15° Lead Angle	GDM 1316 R/L-003PF-15D 1516 R/L-003PF-15D 1516R-015PF-15D 2020 R/L-003PF-15D 2020R-015PF-15D 2520 R/L-003PF-15D 2520R-015PF-15D 3020 R/L-003PF-15D 3020R-015PF-15D	1.3	±0.04	0.03	1.0	16		3.7	●	●	●			
			1.5	0.03	1.2	●				●	●				
			2.0	0.03	1.7	●				●	●				
			2.5	0.15	2.1	●				●	●				
			3.0	0.15	2.3	●				●	●				
			3.0	0.15	2.3	●				●	●				
 Cut-Off (Medium Feed)	GDM 2020N-010PQ 2520N-010PQ 3020N-010PQ	2.0	±0.03	0.1	1.7	20	4.3	●	●	●					
		2.5	0.1	2.1	●			●	●						
		3.0	0.1	2.3	●			●	●						
	 15° Lead Angle	GDM 2020R-010PQ-15D 2520R-010PQ-15D 3020R-010PQ-15D	2.0	±0.03	0.1	1.7	20	4.3	15°	R	R	R			
			2.5	0.1	2.1	R			R	R					
			3.0	0.1	2.3	R			R	R					
 Cut-Off (Low Cutting Force)	GDG 2020N-005PG 2520N-005PG 3020N-005PG	2.0	±0.02	0.05	1.7	20	4.3	—	●	●	●	●			
		2.5	0.05	2.1	●			●	●	●					
		3.0	0.05	2.3	●			●	●	●					
	 15° Lead Angle	GDG 2020R-005PG-15D 2520R-005PG-15D 3020R-005PG-15D	2.0	±0.02	0.05	1.7	20	4.3	15°	R	R	R	R		
			2.5	0.05	2.1	R			R	R	R				
			3.0	0.05	2.3	R			R	R	R				

PF chipbreaker has a large corner-R(re)
Using PF chipbreaker (designed for cut-off) for grooving
will not create a flat bottom (See Fig.)



Groove bottom created by PF chipbreaker

Inserts are sold in 10 piece boxes

● : Standard Stock R : Standard Stock (Right-hand Only)

GDM/GDMS (Cut-Off)

Insert		Description	Dimensions(mm)					Angle	MEGACOAT							
			W	re	M	L	H	θ	PR1535	PR1225	PR1215					
Cut-Off	Handed Insert shows Right-hand	GDM	2020N-020PM	2.0	±0.03	0.2	1.5	20	4.3	—	●	●	●			
			2520N-020PM	2.5		0.2	1.95				●	●	●			
			3020N-025PM	3.0		0.25	2.3				●	●	●			
			4020N-030PM	4.0		0.3	3.3				●	●	●			
	6° Lead Angle	GDM	2020R-020PM-6D	2.0	±0.03	0.2	1.5	20	4.3	6°	R	R	R			
			2520R-020PM-6D	2.5		0.2	1.95				R	R	R			
			3020R-025PM-6D	3.0		0.25	2.3				R	R	R			
			4020R-030PM-6D	4.0		0.3	3.3				R	R	R			
	1-edge	GDMS	2020N-020PM	2.0	±0.03	0.2	1.5	20	4.3	—	●	●	●			
			3020N-025PM	3.0		0.25	2.3				●	●	●			
			4020N-030PM	4.0		0.3	3.3				●	●	●			
			2020R-020PM-6D	2.0		0.2	1.5				R	R	R			
	6° Lead Angle 1-edge	GDMS	3020R-025PM-6D	3.0	±0.03	0.25	2.3	20	4.3	6°	R	R	R			
			4020R-030PM-6D	4.0		0.3	3.3				R	R	R			

Using PM chipbreaker (designed for cut-off) for grooving will not create a flat bottom (See Fig.)  Groove bottom created by PM chipbreaker ● : Standard Stock R : Standard Stock (Right-hand Only)

Inserts Identification System

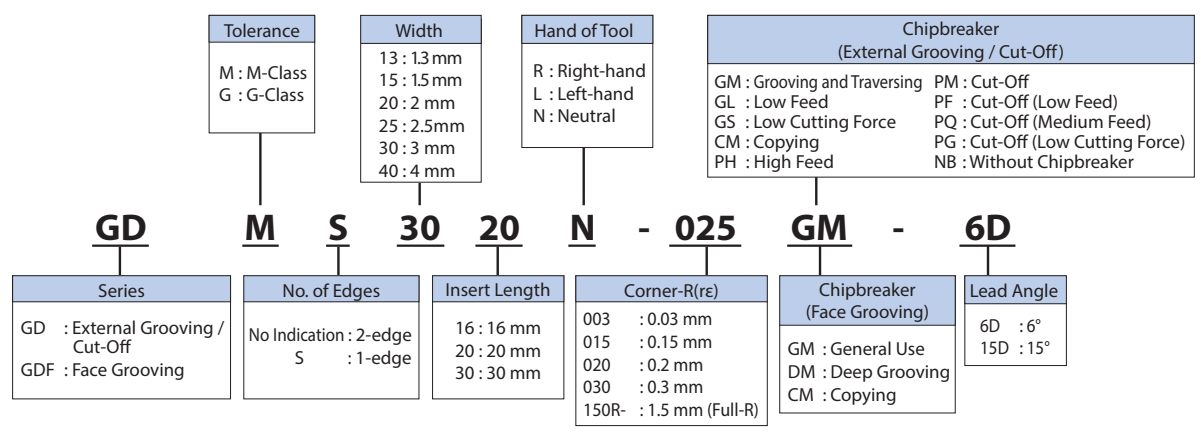

Setting the Insert

1. Completely eliminate chips from the insert mounting part. (see Fig.1)
2. Put the insert into the toolholder and push until it contacts the holder's surface for fixing the insert's back end. (see Fig.1, Fig.2)
3. Keeping the insert pushed against the toolholder's locating surface, tighten the insert clamp bolt at an appropriate torque. (Recommended tightening torque for clamp bolt is 6.5N·m for HH5X○○, 8.0N·m for HH6X25, and 2.5N·m for SE-50125TR)
4. Make sure there is no gap between the insert and the toolholder's locating surface and that the insert is set straight. (see Fig.2, Fig.3)

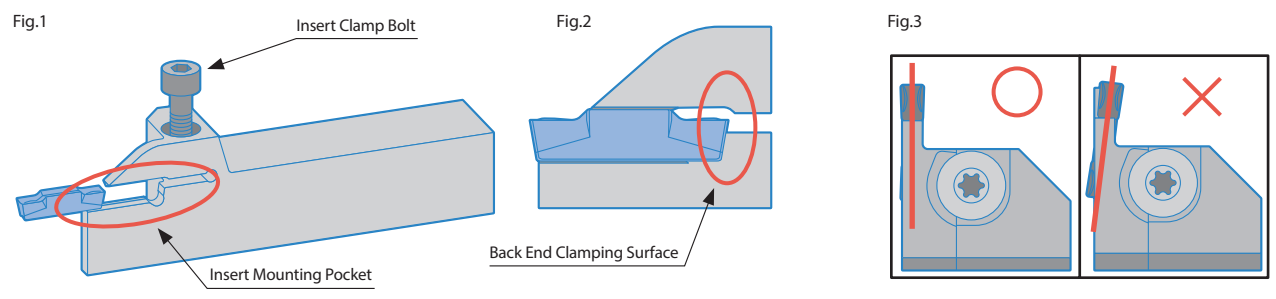

KGD (Integral Type)

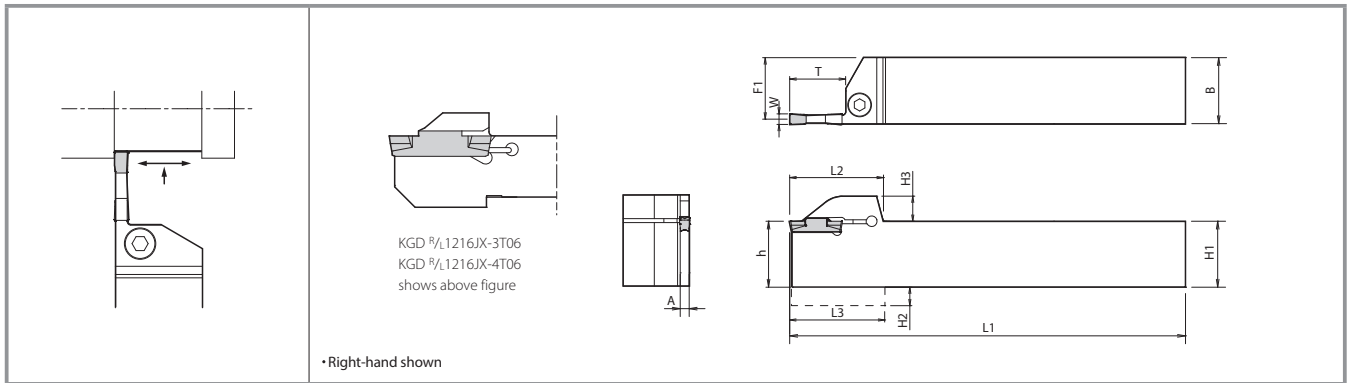

Toolholder Dimensions

Width (mm)	Max. Grooving Depth (mm)	Description	Stock		Dimensions (mm)										Insert Width W(mm)		Spare Parts							
			R	L	H1=h	H2	H3	B	L1	L2	L3	F1	A	T	MIN.	MAX.	Clamp Bolt	Wrench						
2	6	KGD R/L 1616H-2T06	●	●	16	4.0	9.5	16	100	27.7	28.0	15.2	1.7	6	2.0	3.0	HH5X16	LW-4						
		2020K-2T06	●	●	20	—		20	125	28.0	—	19.2					HH5X25							
		2525M-2T06	●	●	25	—		25	150	—	24.2	HH5X16												
	10	KGD R/L 1616H-2T10	●	●	16	4.0		16	100	30.2	30.5	15.2					HH5X25							
		2020K-2T10	●	●	20	—		20	125	30.5	—	19.2					HH5X16							
		2525M-2T10	●	●	25	—		25	150	—	24.2	HH5X25												
	17	KGD R/L 1616H-2T17	●	●	16	4.0		16	100	31.2	31.5	15.2		HH5X16										
		2012K-2T17	●	●	20	—		12	125	—	11.2	HH5X25												
		2020K-2T17	●	●	20	—		20	125	32.5	—	19.2		HH5X16										
	17	2525M-2T17	●	●	25	—		25	150	—	24.2	HH5X25												
		2.4	KGD R/L 2012K-2.4T17	●	●	20		—	9.5	12	125	32.5		—			11.0		2.0	17	2.4	3.0	HH5X16	LW-4
			2020K-2.4T17	●	●	20		—	9.5	20	—	19.0		HH5X16										
3	6	KGD R/L 1216JX-3T06	●	●	12	2.0	5.5	16	120	19.5	19	14.8	2.4	10	3.0	4.0	SE-50125TR	LTW-20						
		1616H-3T06	●	●	16	4.0	16	100	27.7	28.0	14.8	HH5X16												
		2020K-3T06	●	●	20	—	20	125	28.0	—	18.8	HH5X25												
		2525M-3T06	●	●	25	—	25	150	—	23.8	HH5X16													
	10	KGD R/L 1616H-3T10	●	●	16	4.0	16	100	30.2	30.5	14.8	HH5X16												
		2020K-3T10	●	●	20	—	20	125	30.5	—	18.8	HH5X25												
		2525M-3T10	●	●	25	—	25	150	—	23.8	HH5X16													
	20	KGD R/L 1616H-3T20	●	●	16	4.0	16	100	34.2	34.5	14.8	HH5X16												
		2012K-3T20	●	●	20	—	12	125	34.5	—	10.8	HH5X25												
		2020K-3T20	●	●	20	—	20	125	—	18.8	HH5X16													
		2525M-3T20	●	●	25	—	25	150	35.5	—	23.8	HH5X25												
	4	KGD R/L 1216JX-4T06	●	●	12	2.0	5.5	16	120	19.5	19	14.3					3.4	6	4.0	5.0	SE-50125TR	LTW-20		
KGD R/L 2020K-4T10		●	●	20	—	20	125	30.5	—	18.3	HH5X16													
2525M-4T10		●	●	25	—	25	150	—	23.3	HH5X25														
KGD R/L 2020K-4T20		●	●	20	—	9.5	20	125	34.5	—	18.3	HH5X16												
20	2525M-4T20	●	●	25	—	9.5	25	150	35.5	—	23.3	HH5X25												
	KGD R/L 2525M-4T25	●	●	25	—	9.5	25	150	40.5	—	23.3	HH5X25												
5	10	KGD R/L 2020K-5T10	●	●	20	—	9.5	20	125	30.5	—	17.8	4.4	10	5.0	6.0		HH5X16			LW-4			
		2525M-5T10	●	●	25	—	9.5	25	150	—	22.8	HH5X25												
	KGD R/L 2020K-5T17	●	●	20	—	9.5	20	125	37.5	—	17.8	HH5X25												
	2525M-5T17	●	●	25	—	9.5	25	150	—	22.8	HH5X25													
25	KGD R/L 2525M-5T25	●	●	25	—	9.5	25	150	40.5	—	22.8	HH5X25												
	6	KGD R/L 2525M-6T15	●	●	25	—	9.5	25	150	32.5	—	22.4	5.3	15	6.0	6.0		HH5X25			LW-4			
KGD R/L 2525M-6T30		●	●	25	—	9.5	25	150	45.5	—	22.4	30												
8	25	KGD R/L 2525M-8T25	●	●	25	7.0	9.5	25	150	43.3	—	44.2	6.0	25	8.0	8.0	HH6X25	LW-5						
		3232P-8T25	●	●	32	—	9.5	32	170	—	29.0	6.0	25	8.0	8.0	HH6X25	LW-5							

Note 1) Dimension T : Maximum depth to which processing can be made. If the dimension T is 20mm or more, the maximum groove-depth of groove made by the 2-edge insert will be 18mm. ● : Standard Stock
 2) Recommended tightening torque for clamp bolt is 6.5N · m for HH5X16, 8.0N · m for HH6X25 and 2.5N · m for SE-50125TR
 3) Above toolholders can also be used for cut-off applications.

KGD-S (0° SwitchBlade Type)

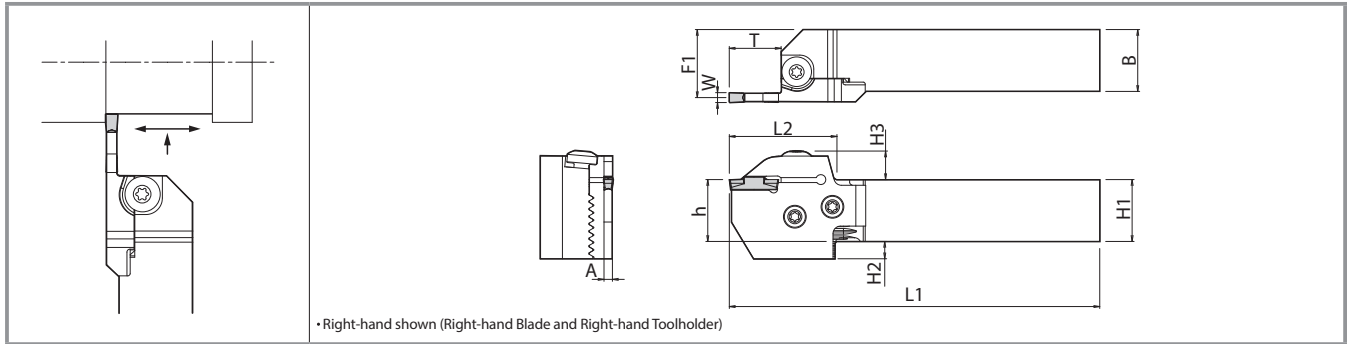

Toolholder Dimensions

Shank Angle	Width (mm)	Max. Grooving Depth (mm)	Shank Size (mm)	Unit Description (Standard Stock Description)	Stock		Blade Description → P10	Toolholder Description → P10	Dimensions(mm)										Insert Width W(mm)									
					R	L			H1=h	H2	H3	B	L1	L2	L3	F1	A	T	MIN.	MAX.								
0°	2	17	□ 20	KGD ^{R/L} 2020X-2T17S	●	●	KGD ^{R/L} -2T17-C	KGD ^{R/L} 2020-C	20	12	11.6	20	122	40	23.4	1.7	17	2.0	3.0									
			□ 25	2525X-2T17S	●	●		KGD ^{R/L} 2525-C	25	7		25	147							28.4								
			□ 32	No Unit Description →	●	●		KGD ^{R/L} 3232-C	32	—		32	167							35.4								
	3	10	□ 20	KGD ^{R/L} 2020X-3T10S	●	●	KGD ^{R/L} -3T10-C	KGD ^{R/L} 2020-C	20	12	11.6	20	115	33	23.0	2.4	10	3.0	4.0									
			□ 25	2525X-3T10S	●	●		KGD ^{R/L} 2525-C	25	7		25	140							28.0								
			□ 32	3232X-3T10S	●	●		KGD ^{R/L} 3232-C	32	—		32	160							35.0								
		20	□ 20	KGD ^{R/L} 2020X-3T20S	●	●	KGD ^{R/L} -3T20-C	KGD ^{R/L} 2020-C	20	12		20	125	43	23.0					2.4	20	3.0	4.0					
			□ 25	2525X-3T20S	●	●		KGD ^{R/L} 2525-C	25	7		25	150											28.0				
			□ 32	3232X-3T20S	●	●		KGD ^{R/L} 3232-C	32	—		32	170											35.0				
	4	10	□ 20	KGD ^{R/L} 2020X-4T10S	●	●	KGD ^{R/L} -4T10-C	KGD ^{R/L} 2020-C	20	12	11.6	20	115	33	22.5	3.4	10	4.0	5.0									
			□ 25	2525X-4T10S	●	●		KGD ^{R/L} 2525-C	25	7		25	140											27.5				
			□ 32	3232X-4T10S	●	●		KGD ^{R/L} 3232-C	32	—		32	160											34.5				
		20	□ 20	KGD ^{R/L} 2020X-4T20S	●	●	KGD ^{R/L} -4T20-C	KGD ^{R/L} 2020-C	20	12		20	125	43	22.5					3.4	20	4.0	5.0					
			□ 25	2525X-4T20S	●	●		KGD ^{R/L} 2525-C	25	7		25	150											27.5				
			□ 32	3232X-4T20S	●	●		KGD ^{R/L} 3232-C	32	—		32	170											34.5				
		25	□ 20	KGD ^{R/L} 2020X-4T25S	●	●	KGD ^{R/L} -4T25-C	KGD ^{R/L} 2020-C	20	12		20	130	48	22.5									3.4	25	4.0	5.0	
			□ 25	2525X-4T25S	●	●		KGD ^{R/L} 2525-C	25	7		25	155															27.5
			□ 32	3232X-4T25S	●	●		KGD ^{R/L} 3232-C	32	—		32	175															34.5
	5	10	□ 20	KGD ^{R/L} 2020X-5T10S	●	●	KGD ^{R/L} -5T10-C	KGD ^{R/L} 2020-C	20	12	11.6	20	115	33	22.0	4.4	10	5.0	6.0									
			□ 25	2525X-5T10S	●	●		KGD ^{R/L} 2525-C	25	7		25	140															27.0
			□ 32	3232X-5T10S	●	●		KGD ^{R/L} 3232-C	32	—		32	160															34.0
		25	□ 20	KGD ^{R/L} 2020X-5T25S	●	●	KGD ^{R/L} -5T25-C	KGD ^{R/L} 2020-C	20	12		20	130	48	22.0					4.4	25	5.0	6.0					
			□ 25	2525X-5T25S	●	●		KGD ^{R/L} 2525-C	25	7		25	155															27.0
			□ 32	3232X-5T25S	●	●		KGD ^{R/L} 3232-C	32	—		32	175															34.0

Note 1) When using the toolholder in normal mounting position, the lower jaw of toolholder may interfere with the tool presetter.

●: Standard Stock

2) The toolholder and blade descriptions are printed on the toolholder body. (Unit description is not printed.)

KGD-S: Right-hand Blade for Right-hand Toolholder, Left-hand Blade for Left-hand Toolholder.

The toolholder is applicable for all blade with suitable hand.

3) In case the unit description is not available (No Unit Description), please purchase toolholder and blade separately.

4) Dimension T: Maximum depth to which processing can be made. If the dimension T is 20mm or more, the maximum groove-depth of groove made by the 2-edge insert will be 18mm.

KGDS-S (90° SwitchBlade Type)

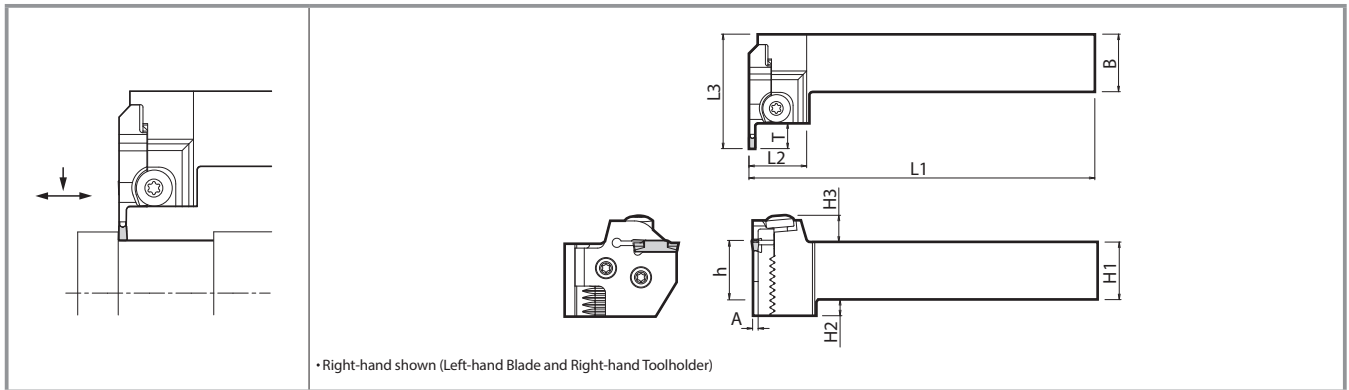

Toolholder Dimensions

Shank Angle	Width (mm)	Max. Grooving Depth (mm)	Shank Size (mm)	Blade Description → P10	Toolholder Description → P10	Unit Description (Standard Stock Description)	Stock	Dimensions (mm)										Insert Width W(mm)		
								R	L	H1=h	H2	H3	B	L1	L2	L3	F1	A	T	MIN.
90°	2	17	□ 20	KGD L/R-2T17-C	KGDS R/L2020-C	—	—	—	20	12	11.6	20	125	27.7	56.7	—	1.7	17	2.0	3.0
			□ 25		KGDS R/L2525-C	—	—	25	7	25		150								
	3	10	□ 20	KGD L/R-3T10-C	KGDS R/L2020-C	KGDS R/L 2020X-3T10S	●	●	20	12	20	125	49.7	2.4	10	3.0	4.0			
			□ 25		KGDS R/L2525-C	2525X-3T10S	●	●	25	7	25	150								
		20	□ 20	KGD L/R-3T20-C	KGDS R/L2020-C	—	—	—	20	12	20	125	59.7							
			□ 25		KGDS R/L2525-C	—	—	25	7	25	150									
	4	10	□ 20	KGD L/R-4T10-C	KGDS R/L2020-C	—	—	—	20	12	20	125	49.7	3.4	20	4.0	5.0			
			□ 25		KGDS R/L2525-C	—	—	25	7	25	150									
		20	□ 20	KGD L/R-4T20-C	KGDS R/L2020-C	—	—	—	20	12	20	125	59.7							
			□ 25		KGDS R/L2525-C	—	—	25	7	25	150									
		25	□ 20	KGD L/R-4T25-C	KGDS R/L2020-C	—	—	—	20	12	20	125	64.7							
			□ 25		KGDS R/L2525-C	—	—	25	7	25	150									
	5	10	□ 20	KGD L/R-5T10-C	KGDS R/L2020-C	—	—	—	20	12	20	125	49.7	4.4	10	5.0	6.0			
			□ 25		KGDS R/L2525-C	—	—	25	7	25	150									
		25	□ 20	KGD L/R-5T25-C	KGDS R/L2020-C	—	—	—	20	12	20	125	64.7							
			□ 25		KGDS R/L2525-C	—	—	25	7	25	150									

Note 1) When using the toolholder in normal mounting position, the lower jaw of toolholder may interfere with the tool presetter.

2) The toolholder and blade descriptions are printed on the toolholder body. (Unit description is not printed.)

KGDS-S: Left-hand Blade for Right-hand Toolholder, Right-hand Blade for Left-hand Toolholder.

The toolholder is applicable for all blade with suitable hand.

3) Dimension T: Maximum depth to which processing can be made. If the dimension T is 20mm or more, the maximum groove-depth of groove made by the 2-edge insert will be 18mm.

●: Standard Stock

Toolholders Identification System(External Grooving, Cut-Off / Integral Type, SwitchBlade Type)

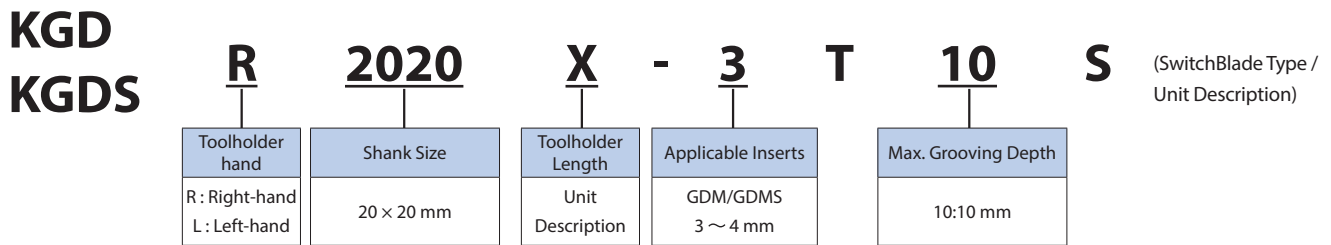
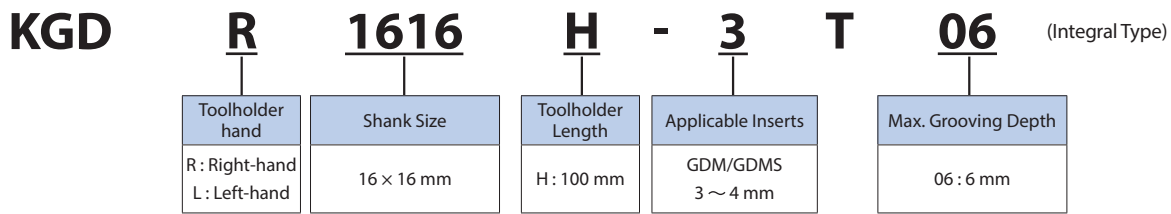

Structure of Toolholder Unit (External Grooving, Cut-Off)

1) 0° SwitchBlade Type

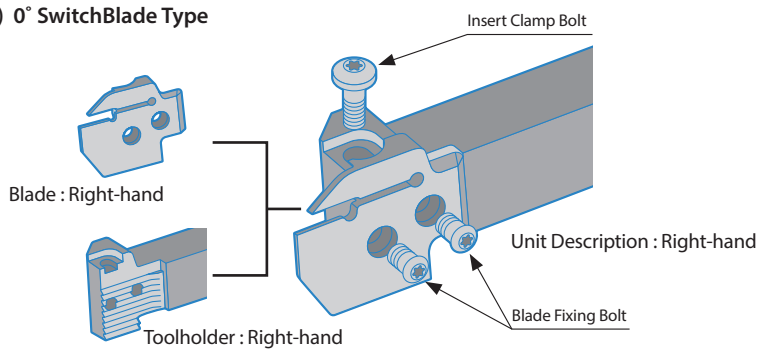

Toolholder (KGD ^{R/L} ●● -C)

+

Blade (KGD ^{R/L} ●T ●● -C)

⇒ Right-hand Blade for Right-hand Toolholder,
Left-hand Blade for Left-hand Toolholder.

2) 90° SwitchBlade Type

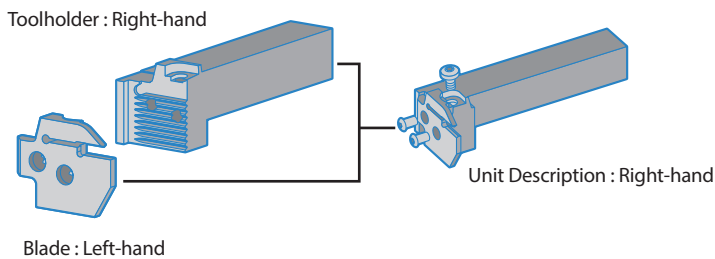

Toolholder (KGDS ^{R/L} ●● -C)

+

Blade (KGD ^{L/R} ●T ●● -C)

⇒ Left-hand Blade for Right-hand Toolholder,
Right-hand Blade for Left-hand Toolholder.

SwitchBlade Type Toolholder Identification System and Their Setting to Lathe

Firmly fit the lower jaw to the tool post of the lathe.

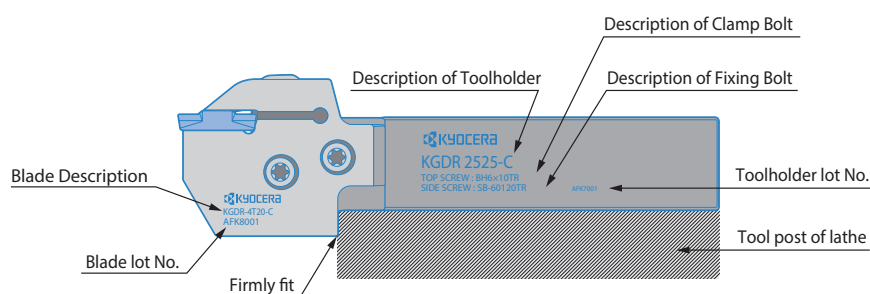

Shape of 0° type Right-hand shown	Toolholder Description	Stock		Dimensions(mm)		
		R	L	L	B	H1
	KGDR ^{R/L} 2020-C	●	●	104	20	20
	2525-C	●	●	129	25	25
	3232-C	●	●	149	32	32
Shape of 90° type Right-hand shown	Toolholder Description	Stock		Dimensions(mm)		
		R	L	L	B	H1
	KGDS ^{R/L} 2020-C	●	●	122	20	20
	2525-C	●	●	147	25	25
Shape of Blade Right-hand shown	Blade Description	Stock		Dimensions(mm)		
		R	L	L	T	A
	KGDR ^{R/L} -2T17-C	●	●	51.2	17.2	1.7
	-3T10-C	●	●	44.2	10.2	2.4
	-3T20-C	●	●	53.2	20.2	
	-4T10-C	●	●	44.2	10.2	3.4
	-4T20-C	●	●	54.2	20.2	
	-4T25-C	●	●	59.2	25.2	4.4
	-5T10-C	●	●	44.2	10.2	
	-5T25-C	●	●	59.2	25.2	

● : Standard Stock

Spare Parts

Spare Parts		
Clamp Bolt (for Insert Clamp)	Clamp Bolt (for Blade)	Wrench
BH6X10TR	SB-60120TR	LTW-25

* The parts are included in the toolholder and unit.

Setting the Blade (SwitchBlade Type Toolholder)

1. Use compressed air or other measures to remove chips and dust from the serration part. (see Fig.1)
2. Mate and fit the serrations of the blade and toolholder, and also fit the blade end to the toolholder. (see Fig.2)
3. Tighten the blade fixing screws at an appropriate torque. You can tighten them in any order. (see Fig.2) (Recommended tightening torque : 8N·m)
4. Set the insert after setting the blade.

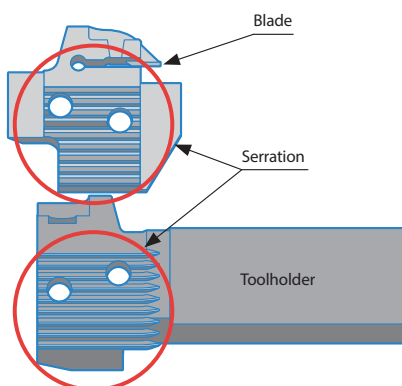

Fig.1

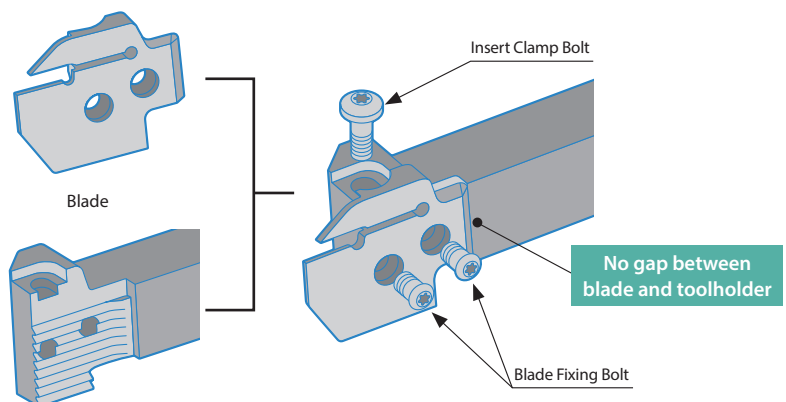
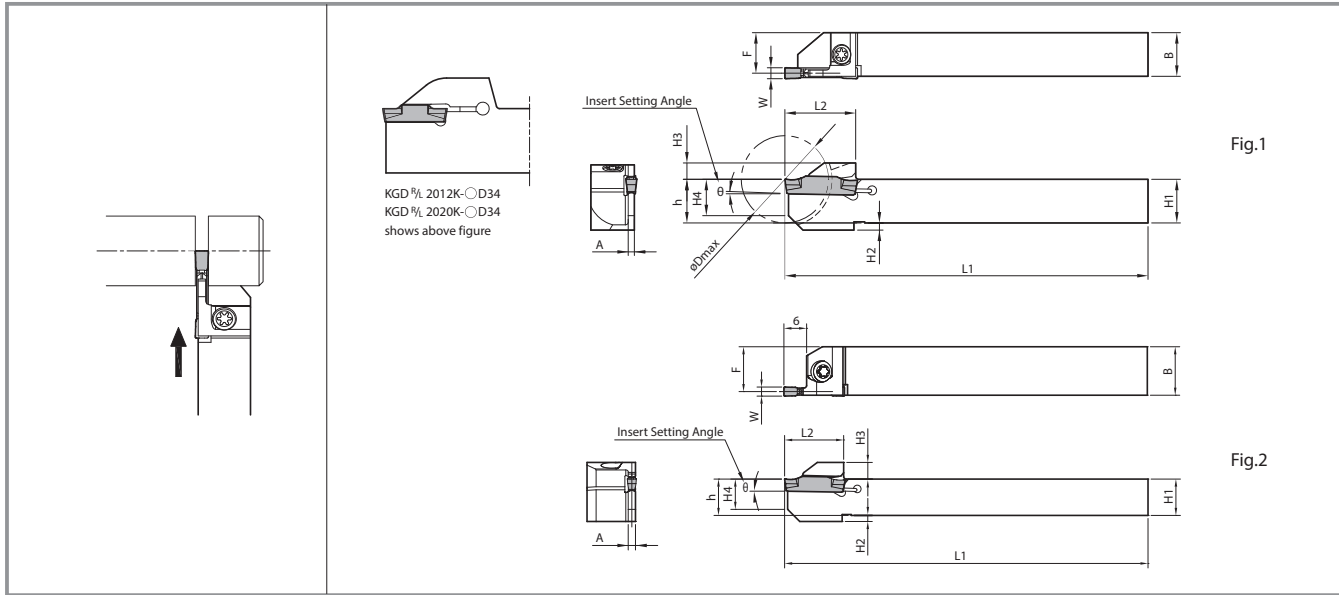

Fig.2

KGD (for Automatic Lathe)

Toolholder Dimensions



Description	Stock		Cut-Off Dia. (mm)	Dimensions(mm)										Angle	Insert Width W(mm)		Drawing	Spare Parts					
	R	L		H1-h	H2	H3	H4	B	L1	L2	F	A	θ		MIN.	MAX.		Screw	Wrench				
	ØDmax	θDmax																					
KGD %L 1010JX-1.3D16	●	●	16	10	2	5.5	8	10	120	18	9.9	1.0	5°	1.3	1.3	Fig.1	SB-40120TR	LTW-15S					
	●	●	20								9.5												
	●	●	16	12	2	5.5	10	12	120	18	85												
	●	●	24								120								19.5	11.9			
	●	●	24								85								11.5				
	●	●	24								120												
KGD %L 1010JX-1.5D16	●	●	16	10	2	5.5	8	10	120	18	9.7	1.2	5°	1.5	1.5	Fig.1	SB-40120TR	LTW-15S					
	●	●	20								9.4												
	●	●	16	12	2	5.5	10	12	120	18	85												
	●	●	24								120								19.5	11.7			
	●	●	24								85								11.4				
	●	●	24								120												
KGD %L 1010JX-2	●	●	20	10	2	5.5	8	10	120	18	9.2	1.6	1°	2.0	3.0	Fig.1	SB-40120TR	LTW-15S					
	●	●	24								12								85	19.5	11.2		
	●	●	24	12	16	120	24.5	15.2															
	●	●	32	16	—	9.5	20	12	125	32.5	11.2		0°				HH5X16	LW-4					
	●	●	34								20								20	19.2			
	KGD %L 1010JX-2.4	●	●	20	10	2	5.5	8	10	120	18		9				2.0	1°	2.4	3.0	Fig.1	SB-40120TR	LTW-15S
●		●	24	12								85	19.5	11									
●		●	24	12	10	120	24.5	15															
●		●	32	16	—	9.5	20	12	125	32.5	11	0°	HH5X16	LW-4									
●		●	34								20				20	19							
KGD %L 1212JX-3		●	●	24	12	2	5.5	8	13	13	125	19.5	2.4	1°	3.0	4.0		Fig.1				SB-40120TR	LTW-15S
	●	●	32	16								—					8		14	20	120		
	●	●	38		19	29	11.8																
	●	●	42	19	—	8.5	14	20	120	31	10.8												
	●	●	51							36	18.8												
	●	●	42	20	—	8.5	14	20	120	31	18.8												
	●	●	51							36	18.8												
	●	●	12	12	2	5.5	10	16	120	19.5	14.8	0°		Fig.2			SE-50125TR		LTW-20				
	KGD %L 1216JX-4T06	●	●	12	12	2	5.5	10	16	120	19.5	14.3		3.4			0°		4.0	5.0	Fig.2	SE-50125TR	LTW-20

Note 1) 4mm width insert can be installed in KGDR/L1212JX-3, but is not recommended due to the toolholder's rigidity.
 2) Recommended tightening torque for clamp screw is 2.0N·m for SB-40120TR, 2.5N·m for SE-50125TR and 6.5N·m for HH5X16.
 3) When machining material greater than ø36mm with KGDR/L...-3D38 or KGDR/L...-3D42 or KGDR/L...-3D51 toolholders, use 1- edge inserts.
 Max. workpiece diameter for 2-edge inserts ø36mm

●: Standard Stock

KGDS (Small Diameter Cut-Off for Sub Spindle)

Toolholder Dimensions

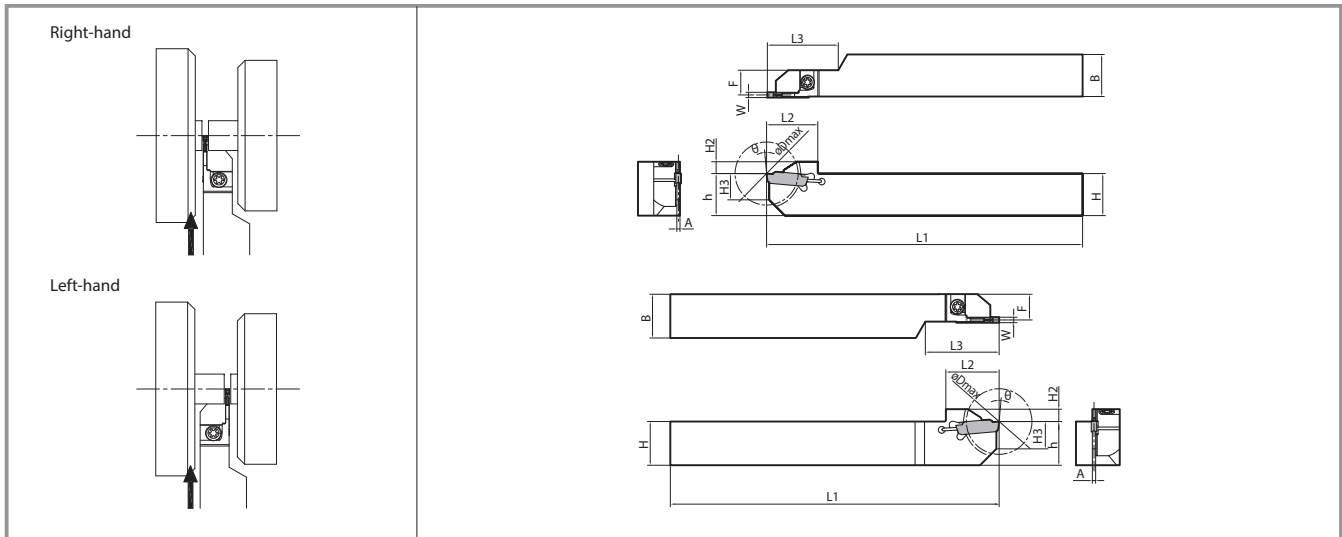

Description	Stock		Cut-Off Dia. (mm)	Dimensions(mm)									Angle	Insert Width W(mm)		Spare Parts	
	R	L		øDmax	H=h	H2	H3	B	L1	L2	L3	F		A	θ	MIN.	MAX.
KGDS % _L 1616JX-1.3B	●	●	24	16	5.5	10	16	120	19.5	27	9.5	1.0	5°	1.3	1.3	SB-40120TR	LTW-15S
	●	●									9.4	1.2		1.5	1.5		
	●	●									9.2	1.6		1°	2.0		

●: Standard Stock

Toolholders Identification System (for Automatic Lathe)

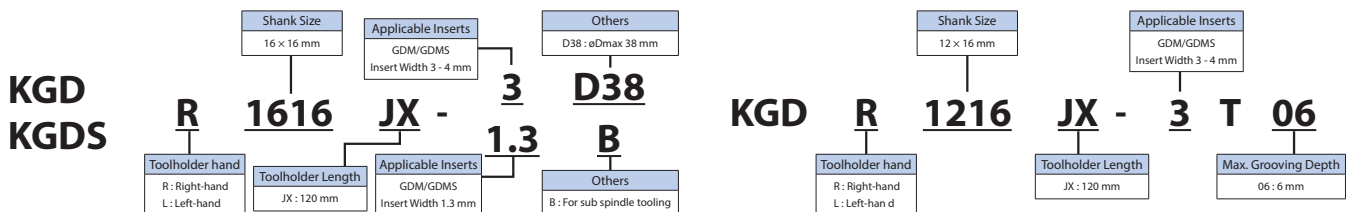

KGDS Selection Reference

KGDS Standard Type

Both Right-hand and Left-hand types are applicable to gang tool post. Left-hand type is recommended for cut-off operations when using a sub-spindle.

KGDR (Right-hand)	KGDL (Left-hand)
1st Recommendation Use insert with lead angle to remove boss • No sub-spindle • Cut-off close to main spindle	1st Recommendation Insert without lead angle • Sub-spindle use • Cut-off close to sub-spindle

KGDS Sub Spindle Type

The KGDS can be used to reduce overhang distance from the main spindle when cutting off small diameter workpieces.

KGDSR (Right-hand)	KGDSL (Left-hand)
• Long workpiece and more rigidity • Cut-off near main spindle	• Short workpiece and less rigidity • Cut-off near sub-spindle

Recommended Cutting Conditions (External Grooving) ★1st Recommendation ☆2nd Recommendation

Workpiece	Chipbreaker	Recommended Insert Grade (Vc : m/min)								Notes	
		Cermet		MEGACOAT NANO	MEGACOAT		Carbide	MEGACOAT CBN	CBN		PCD
		TN620	TN90	PR1535	PR1225	PR1215	GW15	KBN05M	KBN570		KPD001
Carbon Steel	GM	☆ 80-220	☆ 100-220	☆ 80-200	★ 80-200	☆ 100-200	—	—	—	—	
Alloy Steel	GL	☆ 70-200	☆ 80-200	☆ 70-180	★ 70-180	☆ 80-180	—	—	—	—	
Stainless Steel	CM	—	—	★ 60-150	☆ 60-150	☆ 60-150	—	—	—	—	
Cast Iron	PH	—	—	—	—	★ 100-200	—	—	—	—	
Aluminum Alloy	GS	—	—	—	—	—	☆ 200-500	—	—	★ 150-2,000	
Brass	NB	—	—	—	—	—	☆ 100-200	—	—	★ 200-800	
Hard materials	NB	—	—	—	—	—	—	★ 80-150	—	—	
Powdered Steel		—	—	—	—	—	—	—	★ 100-250	—	

Recommended Cutting Conditions (Feed Rate / D.O.C.)

(Workpiece : S50C)

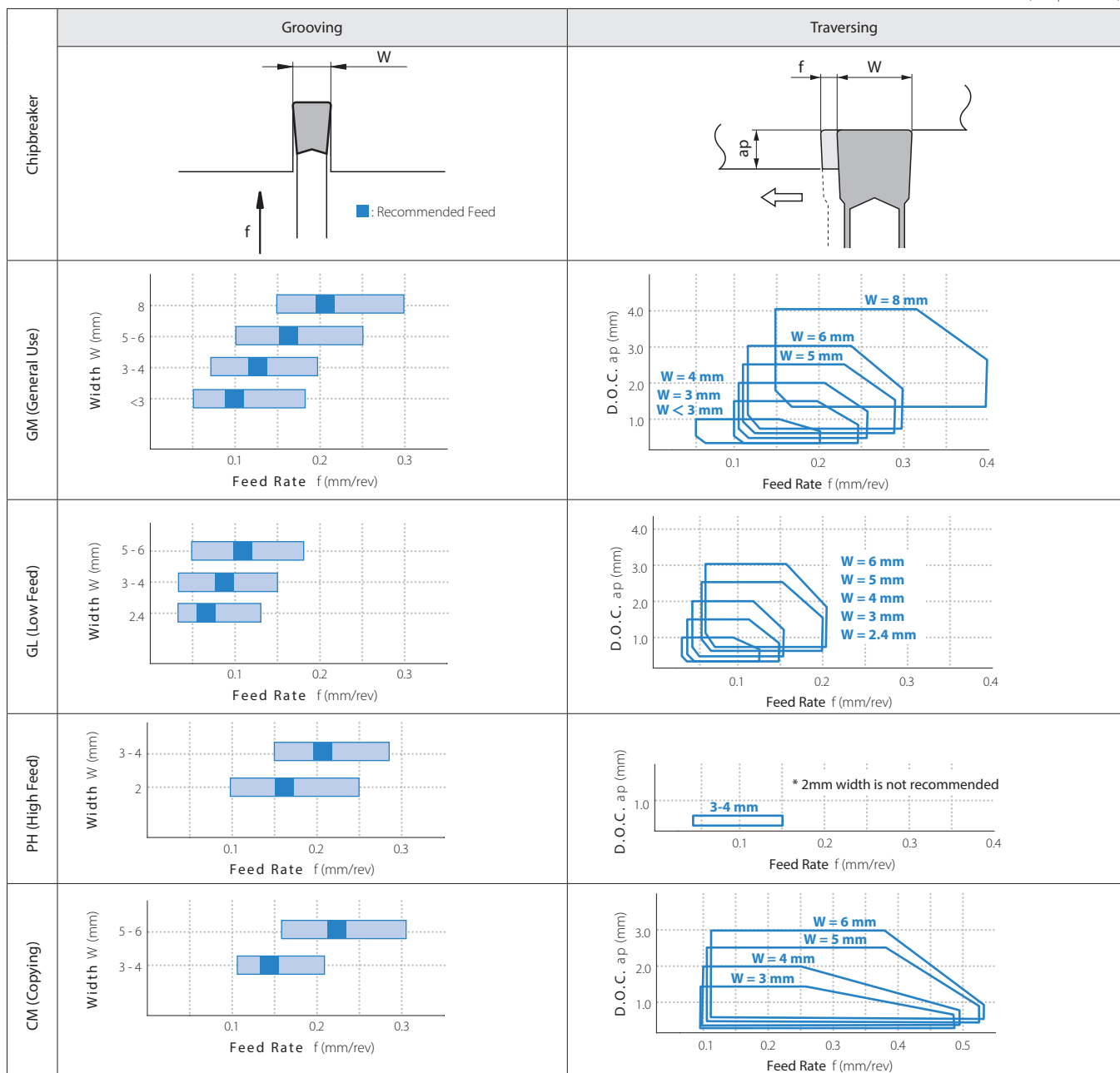

1) The above values reflect a T dimension that is 17mm or less.

2) If the toolholder is not for the 8mm width insert and its T dimension is over 17mm, set the values for traversing to less than 90% of recommended cutting conditions above.

Recommended Cutting Conditions (External Grooving)

Recommended Cutting Conditions (Feed Rate / D.O.C.) (Workpiece: S50C)

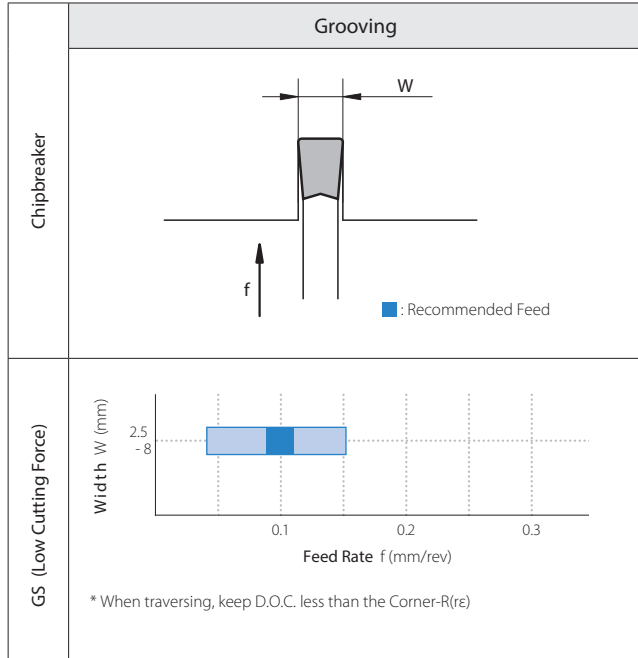

1) The above values reflect a T dimension that is 17mm or less.

Recommended Cutting Conditions (Feed Rate)

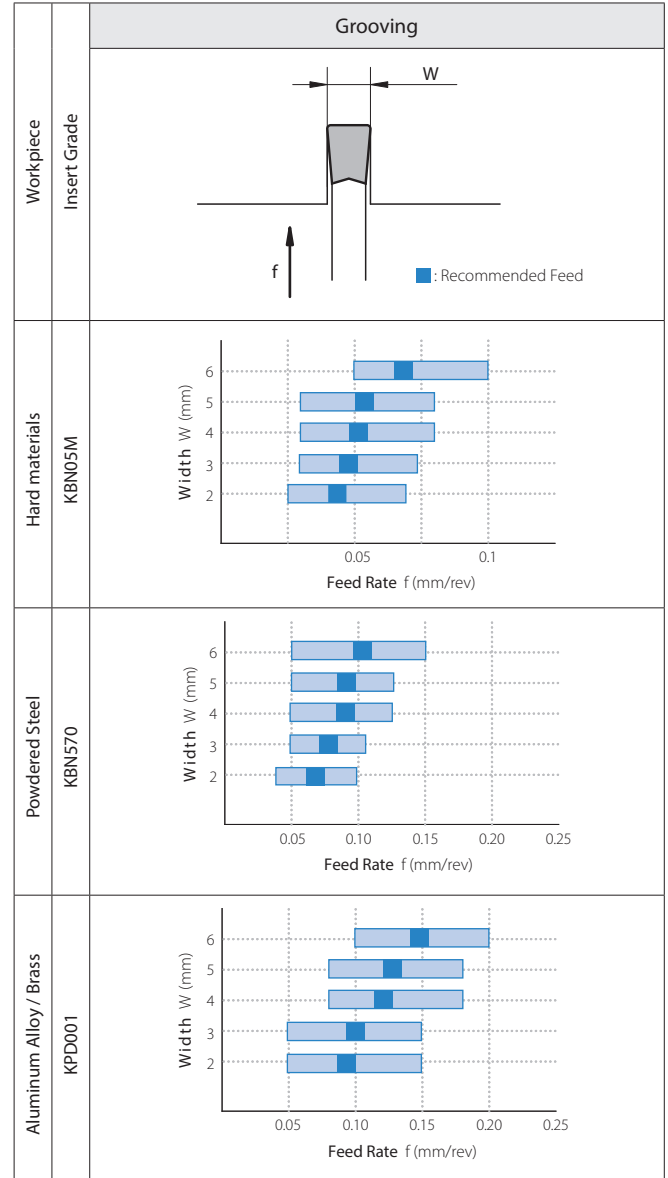

CM Chipbreaker (Back Turning)

Estimated maximum cutting amount (D.O.C.) for back turning

Description	Max. D.O.C. (ap : mm)				
	Toolholder Description				
	KGD...-2T...	KGD...-3T...	KGD...-4T...	KGD...-5T...	KGD...-6T...
GDM 3020N-150R-CM	0.24	0.20	—	—	—
4020N-200R-CM	—	0.24	0.20	—	—
5020N-250R-CM	—	—	0.30	0.20	—
6020N-300R-CM	—	—	—	0.30	0.25

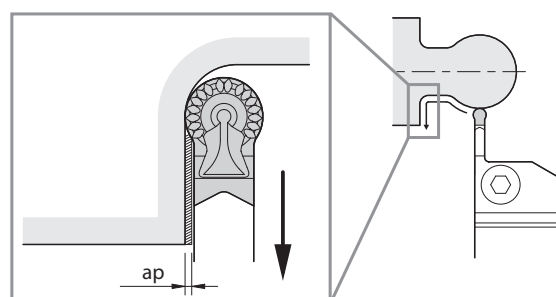

Recommended Cutting Conditions (Cut-off, PF / PQ / PG Chipbreakers) ★1st Recommendation ☆2nd Recommendation

Workpiece	Cutting Conditions (Vc:m/min)					Feed Rate (f:mm/rev)										Notes
	Recommended Insert Grade					PF(Corner-R (r _e) = 0.03)			PF(Corner-R (r _e) = 0.15)			PQ		PG		
	MEGACOAT NANO	MEGACOAT		DLC Coated Carbide	Carbide	Insert Width W(mm)			Insert Width W(mm)			Insert Width W(mm)		Insert Width W(mm)		
	PR1535	PR1225	PR1215	PDL025	GW15	1.3/1.5	2.0	2.5/3.0	1.3/1.5	2.0	2.5/3.0	2.0	2.5/3.0	2.0	2.5/3.0	
Carbon Steel	☆ 70 – 150	★ 70 – 150	☆ 70 – 180	—	—	0.01 –0.04	0.02 –0.06	0.02 –0.08	0.01 –0.05	0.03 –0.08	0.04 –0.10	0.03 –0.1	0.04 –0.12	0.01 –0.04	0.01 –0.05	
Alloy Steel	☆ 70 – 150	★ 70 – 150	☆ 70 – 180	—	—	0.01 –0.03	0.01 –0.04	0.01 –0.05	0.01 –0.04	0.03 –0.07	0.04 –0.08	0.02 –0.07	0.02 –0.08	0.01 –0.03	0.01 –0.04	
Stainless Steel	★ 60 – 120	☆ 60 – 120	☆ 60 – 150	—	—	0.01 –0.03	0.01 –0.04	0.01 –0.05	0.01 –0.04	0.03 –0.07	0.04 –0.08	0.02 –0.07	0.02 –0.08	0.01 –0.03	0.01 –0.04	
Cast Iron	—	—	★ 80 – 200	—	☆ 50 – 100	0.01 –0.05	0.02 –0.07	0.03 –0.08	0.01 –0.06	0.03 –0.09	0.04 –0.10	0.04 –0.1	0.04 –0.12	0.01 –0.04	0.01 –0.05	
Aluminum Alloy	—	—	—	★ 200 – 500	☆ 200 – 450	—	—	—	—	—	—	—	—	0.01 –0.05	0.01 –0.06	
Brass	—	—	—	—	★ 100 – 200	—	—	—	—	—	—	—	—	0.01 –0.07	0.01 –0.08	

Recommended Cutting Conditions (Cut-off, PM Chipbreaker) ★1st Recommendation ☆2nd Recommendation

Workpiece	Cutting Conditions (Vc:m/min)			Feed Rate (f:mm/rev)	Notes
	Recommended Insert Grade			PM	
	MEGACOAT NANO	MEGACOAT		Insert Width W(mm)	
	PR1535	PR1225	PR1215	2.0 – 4.0	
Carbon Steel	☆ 80 – 200	★ 80 – 200	☆ 100 – 200	0.08 – 0.18	Coolant
Alloy Steel	☆ 70 – 180	★ 70 – 180	☆ 80 – 180		
Stainless Steel	★ 60 – 150	☆ 60 – 150	☆ 60 – 150	0.06 – 0.12	
Cast Iron	—	—	★ 100 – 200	0.08 – 0.18	

Machining Tips

Minimum Overhand Length (L2) of the Toolholder

Advantage 1 Compatible with any machine setups regardless of overhang length specifications

Advantage 2 Minimum and optimal overhang length helps to control chattering

Product Lineup with a Maximum Cutting Diameter of 51 mm

Note :

When machining large cutting dia. (over 36 mm) with KGDR/L...-3D38 or KGDR/L...-3D42 or KGDR/L...-3D51, please follow the instructions below.

• Use 1-edge inserts

• Maximum workpiece diameter for 2-edge inserts is ø 36 mm

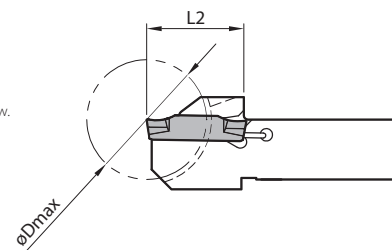

Guide for External Grooving

1) Traversing After Grooving

1. Grooving Depths Over 0.5mm : At Roughing (see Fig.1)
Before traversing, pull the tool back about 0.1mm after grooving,
instead of traversing subsequent to grooving.
(Failure to pull the tool back before traverse cutting will result in an unbalanced load applied on only one side of the cutting edge.)

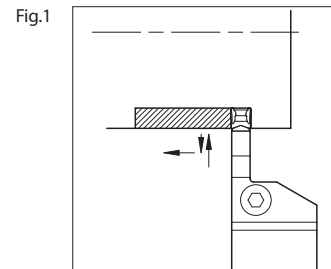

Fig.1
Before traversing, pull the tool back about 0.1mm after grooving.
(Grooving depth over 0.5mm : At roughing)

2. Grooving Depths Under 0.5mm : At Finishing (see Fig.2)
Traversing subsequent to grooving is possible because shallow groove depths relate a small load on the cutting edge.
(Dwell-motion is not necessary)

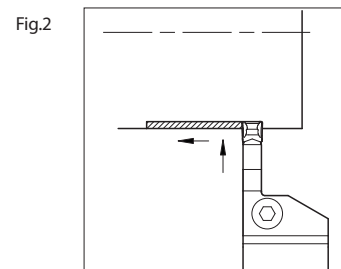
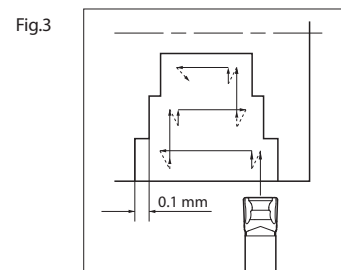

Fig.2
Traversing subsequent to grooving.
(Grooving depth under 0.5mm : At Finishing)

2)

1. When widening the groove width, apply the "Step Turning" as shown in Fig.3
2. The widened groove and side walls should be finished last.
(For better chip control, D.O.C. over 0.5mm is recommended.)
Note: If the workpiece is not supported at the center, reduce the feed rate when grooving towards center



Face Grooving

KGDF

Good chip control

MEGACOAT coating technology for long tool life and high efficiency machining

1 Wide Range of Chipbreakers Available for Face Grooving

Chipbreaker Selection

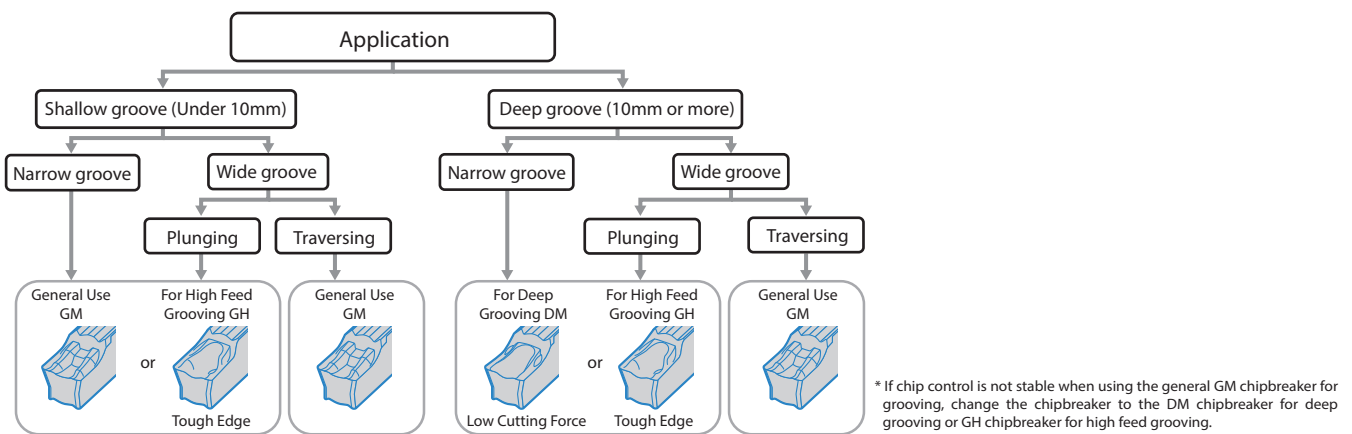

2 MEGACOAT Coating Technology for Long Tool Life

Coating Properties

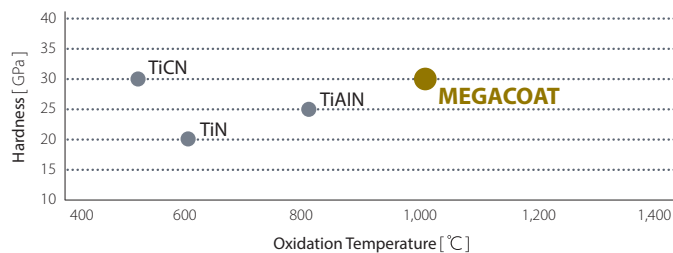

PR1225 (MEGACOAT)

1st. Recommendation for face grooving

PR1215 (MEGACOAT)

Superior wear resistance,

1st. Recommendation for machining of cast iron

3 High Clamping Strength

Prevents abnormal machining surface and / or insert breakage resulting from slip of insert.
Improves repetitive installation accuracy of insert

New insert clamping system "W Grip"

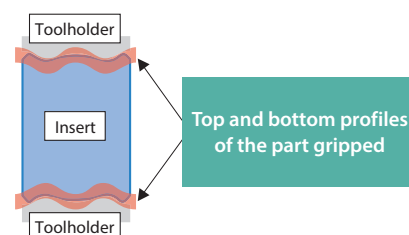

GDFM/GDFMS (Face Grooving)

Applicable Inserts

Insert		Description	Dimensions (mm)						Cermet		MEGACOAT			
			W	Tolerance	rε	M	L	H	TN620	TN90	PRT25	PRT15		
													Classification of usage	
Grooving and Traversing			GDFM 2020N-020GM	2.0		0.2	1.5	21	3.9		●	●	⊕	
			GDFM 3020N-030GM	3.0	±0.03	0.3	2.1		4.3			●	●	⊕
Grooving and Traversing (High Feed)			GDFM 4020N-040GM	4.0			3.1				●	●	●	
			GDFM 5020N-040GM	5.0		0.4						●	●	●
			GDFM 5020N-080GM	5.0		0.8	20	4.5				●	●	●
			GDFM 6020N-040GM	6.0	±0.04	0.4						●	●	●
			GDFM 6020N-080GM	6.0		0.8	5.0					●	●	●
			GDFM 4020N-040GH	4.0	±0.03	0.4							●	●
Deep Grooving and Traversing			GDFM 3020N-030DM	3.0	±0.03	0.3	2.1		4.3		●	●	●	
			GDFM 4020N-040DM	4.0			3.1	20			●	●	●	
			GDFM 5020N-040DM	5.0	±0.04	0.4	4.1		4.5			●	●	●
			GDFM 6020N-040DM	6.0			5.0					●	●	●
			GDFMS 3020N-030DM	3.0	±0.03	0.3	2.1		4.3			●	●	●
Full-R			GDFM 4020N-040DM	4.0			3.1	20			●	●	●	
			GDFM 5020N-040DM	5.0	±0.04	0.4	4.1		4.5			●	●	●
			GDFM 6020N-040DM	6.0			5.0					●	●	●
			GDFM 3020N-150R-CM	3.0	±0.03	1.5	2.1	20	4.3	●		●	●	
			GDFM 4020N-200R-CM	4.0		2.0	3.1	*21		●		●	●	
			GDFM 5020N-250R-CM	5.0	±0.04	2.5	4.1		4.5		●		●	●
			GDFM 6020N-300R-CM	6.0		3.0	5.0	*22		●		●	●	

* GDFM40/50/60-CM differs from other descriptions in length (L) to avoid interference of a toolholder with workpiece.

Inserts Identification System

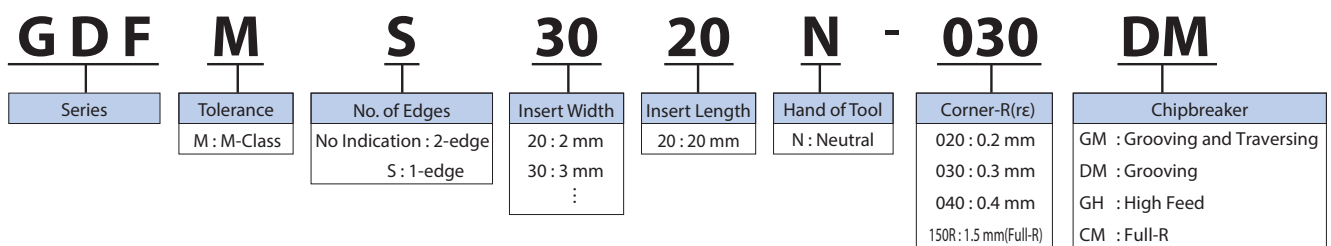

KGDF (Face Grooving / SwitchBlade Type)

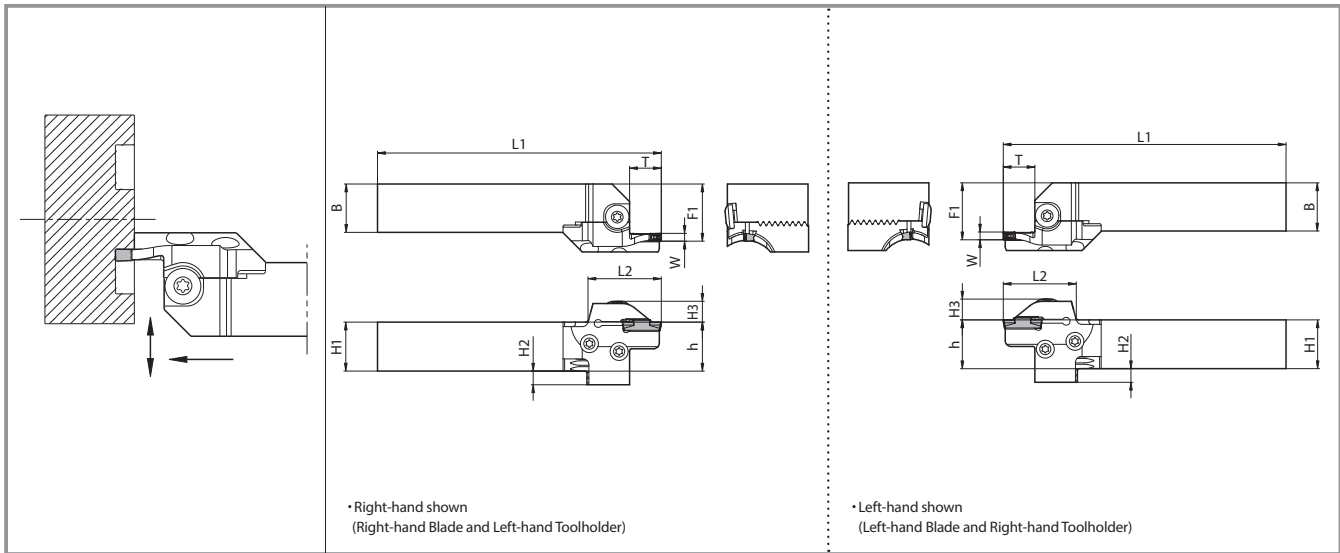

• Right-hand shown
(Right-hand Blade and Left-hand Toolholder)

• Left-hand shown
(Left-hand Blade and Right-hand Toolholder)

Toolholder Dimensions

Shank Angle	Insert Width W (mm)	Shank Size (mm)	Max. Grooving Depth (mm)	Face Grooving Dia. ϕ D (mm)		Unit Description (Standard Stock Description)	Stock		Blade Description → P25	Toolholder Description → P10	Dimensions(mm)										
				MIN.	MAX.		R	L			H1=h	H2	H3	B	L1	L2	F1	T			
0°	20	6	25	30	KGDFR 2020X25-2AS	●	—	KGDFR -25-2A-C	KGDL2020-C	20	12	11.6	20	115	33	24.5	6				
			30	35		●	—											-30-2A-C			
			35	45		●	—											-35-2A-C			
			45	60		●	—											-45-2A-C			
			60	80		●	—											-60-2A-C			
			80	100		●	—											-80-2A-C			
		100	130	●	—	-100-2A-C															
		15	25	30	No Unit Description →					-25-2B-C	118	36	15								
			30	35	No Unit Description →					-30-2B-C											
			35	45	No Unit Description →					-35-2B-C											
			45	60	No Unit Description →					-45-2B-C											
			60	80	No Unit Description →					-60-2B-C											
	80		100	No Unit Description →				-80-2B-C													
	100	130	No Unit Description →				-100-2B-C														
	25	6	25	30	KGDFR 2525X25-2AS	●	—	KGDFR -25-2A-C	KGDL2525-C	25	7	11.6	25	140	33	29.5	6				
			30	35		●	—											-30-2A-C			
			35	45		●	—											-35-2A-C			
			45	60		●	—											-45-2A-C			
			60	80		●	—											-60-2A-C			
			80	100		●	—											-80-2A-C			
		100	130	●	—	-100-2A-C															
		15	25	30	No Unit Description →					-25-2B-C	143	36	15								
			30	35	No Unit Description →					-30-2B-C											
			35	45	No Unit Description →					-35-2B-C											
45			60	No Unit Description →				-45-2B-C													
60			80	No Unit Description →				-60-2B-C													
80	100		No Unit Description →				-80-2B-C														
100	130	No Unit Description →				-100-2B-C															
32	6	25	30	No Unit Description →				-25-2A-C	KGDL3232-C	32	—	11.6	32	160	33	36.5	6				
		30	35	No Unit Description →				-30-2A-C													
		35	45	No Unit Description →				-35-2A-C													
		45	60	No Unit Description →				-45-2A-C													
		60	80	No Unit Description →				-60-2A-C													
		80	100	No Unit Description →				-80-2A-C													
	100	130	No Unit Description →				-100-2A-C														
	15	25	30	No Unit Description →				-25-2B-C		163	36	15									
		30	35	No Unit Description →				-30-2B-C													
		35	45	No Unit Description →				-35-2B-C													
		45	60	No Unit Description →				-45-2B-C													
		60	80	No Unit Description →				-60-2B-C													
80		100	No Unit Description →				-80-2B-C														
100	130	No Unit Description →				-100-2B-C															

Note 1) In case the unit description is not available (No Unit Description), please purchase toolholder and blade separately.

2) Dimension T: Maximum depth to which processing can be made. If the dimension T is 20mm or more, the maximum groove-depth of groove made by the 2-edge insert will be 18mm.

●: Standard Stock
→ P18: Applicable Inserts

KGDF (Face Grooving / SwitchBlade Type)

Toolholder Dimensions

Shank Angle	Insert Width W (mm)	Shank Size (mm)	Max. Grooving Depth (mm)	Face Grooving Dia. øD (mm)		Unit Description (Standard Stock Description)		Stock		Blade Description ➔ P25	Toolholder Description ➔ P10	Dimensions (mm)									
				MIN.	MAX.	R	L	H1=h	H2			H3	B	L1	L2	F1	T				
0°	3	□ 20	13	25	30	KGDF R/L	2020X25-3AS	●	●	KGDF R/L	-25-3A-C	KGD 1/2r2020-C	20	12	11.6	20	118	36	24.5	13	
				30	40		2020X30-3AS	●	●		-30-3A-C										
				40	50		2020X40-3AS	●	●		-40-3A-C										
			15	50	65	2020X50-3BS	●	●	-50-3B-C												
				65	85	2020X65-3BS	●	●	-65-3B-C												
				85	110	2020X85-3BS	●	●	-85-3B-C												
		22	110	145	2020X110-3BS	●	●	-110-3B-C													
			50	65	2020X50-3CS	●	●	-50-3C-C													
			65	85	2020X65-3CS	●	●	-65-3C-C													
		25	85	110	2020X85-3CS	●	●	-85-3C-C													
			110	145	2020X110-3CS	●	●	-110-3C-C													
			□ 25	13	25	30	KGDF R/L	2525X25-3AS	●	●	KGDF R/L						-25-3A-C	KGD 1/2r2525-C	25	7	11.6
	30	40			2525X30-3AS	●		●	-30-3A-C												
	40	50			2525X40-3AS	●		●	-40-3A-C												
	15	50		65	2525X50-3BS	●	●	-50-3B-C													
		65		85	2525X65-3BS	●	●	-65-3B-C													
		85		110	2525X85-3BS	●	●	-85-3B-C													
	22	110		145	2525X110-3BS	●	●	-110-3B-C													
		50		65	2525X50-3CS	●	●	-50-3C-C													
		65		85	2525X65-3CS	●	●	-65-3C-C													
	25	85		110	2525X85-3CS	●	●	-85-3C-C													
		110		145	2525X110-3CS	●	●	-110-3C-C													
		□ 32		13	25	30	No Unit Description ➔				KGDF R/L	-25-3A-C	KGD 1/2r3232-C	32	—	11.6	32				
	30		40		-30-3A-C																
	40		50		-40-3A-C																
	15		50	65	-50-3B-C																
			65	85	-65-3B-C																
			85	110	-85-3B-C																
	22		110	145	-110-3B-C																
			50	65	-50-3C-C																
			65	85	-65-3C-C																
	25		85	110	-85-3C-C																
			110	145	-110-3C-C																
			0°	4	□ 20	13	25	35	KGDF R/L	2020X25-4AS	●	●						KGDF R/L	-25-4A-C	KGD 1/2r2020-C	20
	35	50					2020X35-4BS	●		●	-35-4B-C										
	50	70					2020X50-4BS	●		●	-50-4B-C										
15	70	100				2020X70-4BS	●	●	-70-4B-C												
	100	150				2020X100-4BS	●	●	-100-4B-C												
	150	220				2020X150-4BS	●	●	-150-4B-C												
22	220	∞			2020X220-4BS	●	●	-220-4B-C													
	35	50			2020X35-4CS	●	●	-35-4C-C													
	50	70			2020X50-4CS	●	●	-50-4C-C													
25	70	100			2020X70-4CS	●	●	-70-4C-C													
	100	150			2020X100-4CS	●	●	-100-4C-C													
	150	220			2020X150-4CS	●	●	-150-4C-C													
220	∞	2020X220-4CS		●	●	-220-4C-C															
	□ 25	13		25	35	KGDF R/L	2525X25-4AS	●	●	KGDF R/L	-25-4A-C	KGD 1/2r2525-C	25	7	11.6	25	143	36	29.5	13	
				35	50		2525X35-4BS	●	●		-35-4B-C										
50				70	2525X50-4BS		●	●	-50-4B-C												
15		70		100	2525X70-4BS	●	●	-70-4B-C													
		100		150	2525X100-4BS	●	●	-100-4B-C													
		150		220	2525X150-4BS	●	●	-150-4B-C													
22		220		∞	2525X220-4BS	●	●	-220-4B-C													
		35		50	2525X35-4CS	●	●	-35-4C-C													
		50		70	2525X50-4CS	●	●	-50-4C-C													
25		70		100	2525X70-4CS	●	●	-70-4C-C													
		100		150	2525X100-4CS	●	●	-100-4C-C													
		150		220	2525X150-4CS	●	●	-150-4C-C													
220	∞	2525X220-4CS		●	●	-220-4C-C															
	□ 32	13		25	35	No Unit Description ➔				KGDF R/L	-25-4A-C	KGD 1/2r3232-C	32	—	11.6	32	163	36	36.5	13	
				35	50	-35-4B-C															
50				70	-50-4B-C																
15		70		100	-70-4B-C																
		100		150	-100-4B-C																
		150		220	-150-4B-C																
22		220		∞	-220-4B-C																
		35		50	-35-4C-C																
		50		70	-50-4C-C																
25		70		100	-70-4C-C																
		100	150	-100-4C-C																	
		150	220	-150-4C-C																	
220	∞	-220-4C-C																			

Note 1) In case the unit description is not available (No Unit Description), please purchase toolholder and blade separately.

2) Dimension T : Maximum depth to which processing can be made. If the dimension T is 20mm or more, the maximum groove-depth of groove made by the 2-edge insert will be 18mm.

● : Standard Stock

Applicable Inserts ➔ P18

KGDF (Face Grooving / SwitchBlade Type)

Toolholder Dimensions

Shank Angle	Insert Width W (mm)	Shank Size (mm)	Max. Grooving Depth (mm)	Face Grooving Dia. ϕ D (mm)		Unit Description (Standard Stock Description)		Stock		Blade Description ➔ P25	Toolholder Description ➔ P10	Dimensions (mm)																		
				MIN.	MAX.	R	L	H1=h	H2			H3	B	L1	L2	F1	T													
0°	5	□ 20	15	25	35	KGDF R/L	2020X25-5BS	●	●	KGDF R/L	-25-5B-C	KGD L/R2020-C	20	12	11.6	20	120	38	15											
				35	50		2020X35-5BS	●	●		-35-5B-C																			
				50	75		2020X50-5BS	●	●		-50-5B-C																			
				75	115		2020X75-5BS	●	●		-75-5B-C																			
				115	180		2020X115-5BS	●	●		-115-5B-C																			
				180	235		2020X180-5BS	●	●		-180-5B-C																			
				235	∞		2020X235-5BS	●	●		-235-5B-C																			
			20	25	35	2020X25-5CS	●	●	-25-5C-C	125	43						20													
				35	50	2020X35-5CS	●	●	-35-5C-C																					
				50	75	2020X50-5CS	●	●	-50-5C-C																					
			25	75	115	2020X75-5CS	●	●	-75-5C-C	130	48						25													
				115	180	2020X115-5CS	●	●	-115-5C-C																					
				180	235	2020X180-5CS	●	●	-180-5C-C																					
				235	∞	2020X235-5CS	●	●	-235-5C-C																					
				32	75	115	No Unit Description ➔		-75-5D-C									137	55	32										
					115	180	No Unit Description ➔		-115-5D-C																					
			180		235	No Unit Description ➔		-180-5D-C																						
			235		∞	No Unit Description ➔		-235-5D-C																						
		□ 25	15	25	35	KGDF R/L	2525X25-5BS	●	●	KGDF R/L	-25-5B-C						KGD L/R2525-C	25	7	11.6	25	145	38	15						
				35	50		2525X35-5BS	●	●		-35-5B-C																			
				50	75		2525X50-5BS	●	●		-50-5B-C																			
				75	115		2525X75-5BS	●	●		-75-5B-C																			
				115	180		2525X115-5BS	●	●		-115-5B-C																			
				180	235		2525X180-5BS	●	●		-180-5B-C																			
				235	∞		2525X235-5BS	●	●		-235-5B-C																			
				20	25		35	2525X25-5CS	●		●														-25-5C-C	150	43	20		
					35		50	2525X35-5CS	●		●														-35-5C-C					
					50		75	2525X50-5CS	●		●														-50-5C-C					
				25	75		115	No Unit Description ➔			-75-5C-C														155	48	25			
					115		180	No Unit Description ➔			-115-5C-C																			
			180		235	No Unit Description ➔		-180-5C-C																						
			235		∞	No Unit Description ➔		-235-5C-C																						
			32		75	115	KGDF R/L	2525X75-5DS	●	●	-75-5D-C											162	55	32						
					115	180		2525X115-5DS	●	●	-115-5D-C																			
				180	235	2525X180-5DS		●	●	-180-5D-C																				
				235	∞	2525X235-5DS		●	●	-235-5D-C																				
			□ 32	15	25	35	No Unit Description ➔				KGDF R/L											-25-5B-C	KGD L/R3232-C	32	—	11.6	32	165	38	15
					35	50	No Unit Description ➔															-35-5B-C								
					50	75	No Unit Description ➔															-50-5B-C								
					75	115	No Unit Description ➔															-75-5B-C								
					115	180	No Unit Description ➔															-115-5B-C								
					180	235	No Unit Description ➔															-180-5B-C								
235	∞	No Unit Description ➔				-235-5B-C																								
20	25	35			No Unit Description ➔				-25-5C-C	170		43	20																	
	35	50			No Unit Description ➔				-35-5C-C																					
	50	75		No Unit Description ➔				-50-5C-C																						
25	75	115		No Unit Description ➔				-75-5C-C	175	48	25																			
	115	180		No Unit Description ➔				-115-5C-C																						
	180	235		No Unit Description ➔				-180-5C-C																						
	235	∞		No Unit Description ➔				-235-5C-C																						
	32	75		115	No Unit Description ➔							-75-5D-C	182	55	32															
		115		180	No Unit Description ➔							-115-5D-C																		
180		235		No Unit Description ➔				-180-5D-C																						
235	∞	No Unit Description ➔				-235-5D-C																								

Note 1) In case the unit description is not available (No Unit Description), please purchase toolholder and blade separately.

2) Dimension T: Maximum depth to which processing can be made. If the dimension T is 20mm or more, the maximum groove-depth of groove made by the 2-edge insert will be 18mm.

●: Standard Stock
Applicable Inserts ➔ P18

KGDF (Face Grooving / SwitchBlade Type)

Toolholder Dimensions

Shank Angle	Insert Width W (mm)	Shank Size (mm)	Max. Grooving Depth (mm)	Face Grooving Dia. øD (mm)		Unit Description (Standard Stock Description)		Stock		Blade Description ➔ P25	Toolholder Description ➔ P10	Dimensions (mm)									
				MIN.	MAX.	R	L	H1=h	H2			H3	B	L1	L2	F1	T				
0°	6	□ 20	15	25	35	KGDF R/L	2020X25-6BS	●	●	KGDF R/L	-25-6B-C	KGD 1/16 2020-C	20	12	11.6	20					
				35	50		2020X35-6BS	●	●		-35-6B-C										
				50	75		2020X50-6BS	●	●		-50-6B-C										
				75	115		2020X75-6BS	●	●		-75-6B-C										
				115	180		2020X115-6BS	●	●		-115-6B-C										
				180	235		2020X180-6BS	●	●		-180-6B-C										
			235	∞	2020X235-6BS	●	●	-235-6B-C													
			20	25	35	2020X25-6CS	●	●	-25-6C-C												
				35	50	2020X35-6CS	●	●	-35-6C-C												
				50	75	2020X50-6CS	●	●	-50-6C-C												
				75	115	2020X75-6CS	●	●	-75-6C-C												
				115	180	2020X115-6CS	●	●	-115-6C-C												
				180	235	2020X180-6CS	●	●	-180-6C-C												
			25	235	∞	2020X235-6CS	●	●	-235-6C-C												
				75	115	No Unit Description ➔				-75-6D-C											
				115	180					-115-6D-C											
				180	235					-180-6D-C											
				235	∞					-235-6D-C											
		75		115					-115-6D-C												
		□ 25	15	25	35	KGDF R/L	2525X25-6BS	●	●	KGDF R/L	-25-6B-C	KGD 1/16 2525-C	25	7	11.6	25					
				35	50		2525X35-6BS	●	●		-35-6B-C										
				50	75		2525X50-6BS	●	●		-50-6B-C										
				75	115		2525X75-6BS	●	●		-75-6B-C										
				115	180		2525X115-6BS	●	●		-115-6B-C										
				180	235		2525X180-6BS	●	●		-180-6B-C										
			235	∞	2525X235-6BS	●	●	-235-6B-C													
			20	25	35	2525X25-6CS	●	●	-25-6C-C												
				35	50	2525X35-6CS	●	●	-35-6C-C												
				50	75	2525X50-6CS	●	●	-50-6C-C												
				75	115	No Unit Description ➔				-75-6C-C											
				115	180					-115-6C-C											
				180	235					-180-6C-C											
			25	235	∞					-235-6C-C											
				75	115	KGDF R/L	2525X75-6DS	●	●	-75-6D-C											
				115	180		2525X115-6DS	●	●	-115-6D-C											
				180	235		2525X180-6DS	●	●	-180-6D-C											
235	∞			2525X235-6DS	●		●	-235-6D-C													
75	115						-75-6D-C														
115	180						-115-6D-C														
□ 32	15	25	35	No Unit Description ➔				KGDF R/L	-25-6B-C	KGD 1/16 3232-C	32	—	11.6	32							
		35	50						-35-6B-C												
		50	75						-50-6B-C												
		75	115						-75-6B-C												
		115	180						-115-6B-C												
		180	235						-180-6B-C												
	235	∞					-235-6B-C														
	20	25	35					-25-6C-C													
		35	50					-35-6C-C													
		50	75					-50-6C-C													
		75	115					-75-6C-C													
		115	180					-115-6C-C													
		180	235					-180-6C-C													
	25	235	∞					-235-6C-C													
		75	115					-75-6D-C													
		115	180					-115-6D-C													
		180	235					-180-6D-C													
		235	∞					-235-6D-C													
75		115					-75-6D-C														
32	115	180					-115-6D-C														
	180	235					-180-6D-C														
	235	∞					-235-6D-C														
	75	115					-75-6D-C														
	115	180					-115-6D-C														
	180	235					-180-6D-C														

Note 1) In case the unit description is not available (No Unit Description), please purchase toolholder and blade separately.

2) Dimension T: Maximum depth to which processing can be made. If the dimension T is 20mm or more, the maximum groove-depth of groove made by the 2-edge insert will be 18mm.

●: Standard Stock

Applicable Inserts ➔ P18

Spare Parts (Common with SwitchBlade types)

Unit Description	Spare Parts		
	Clamp Bolt (for Insert Clamp)	Clamp Bolt (for Blade)	Wrench
KGDF ^{R/L} •••S	BH6X10TR	SB-60120TR	LTW-25

* The parts are included in the toolholder and unit.

KGDF Toolholder Assembly Identification (Face Grooving / SwitchBlade Type)

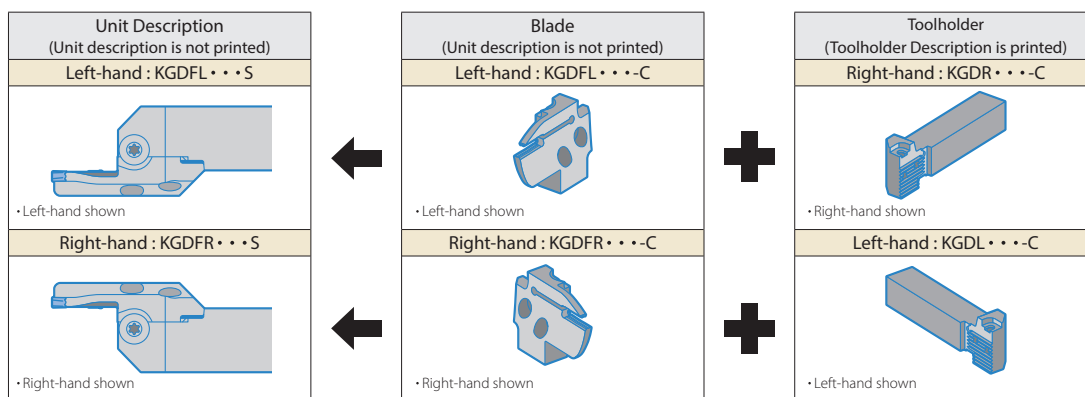

- Right-hand Blade for Left-hand Toolholder, Left-hand Blade for Right-hand Toolholder.
- The Unit Description is not printed on the product. It is printed on the box label.
- Combination of the toolholder and blade (both separately sold) can make up the corresponding assembly.
- The insert clamping bolt (BH6x10TR), blade fixing bolt (SB-60120TR) and wrench (LTW-25) which are included in the toolholder can be used.

Face Grooving Toolholder Assembly Identification System (Face Grooving / SwitchBlade Type)

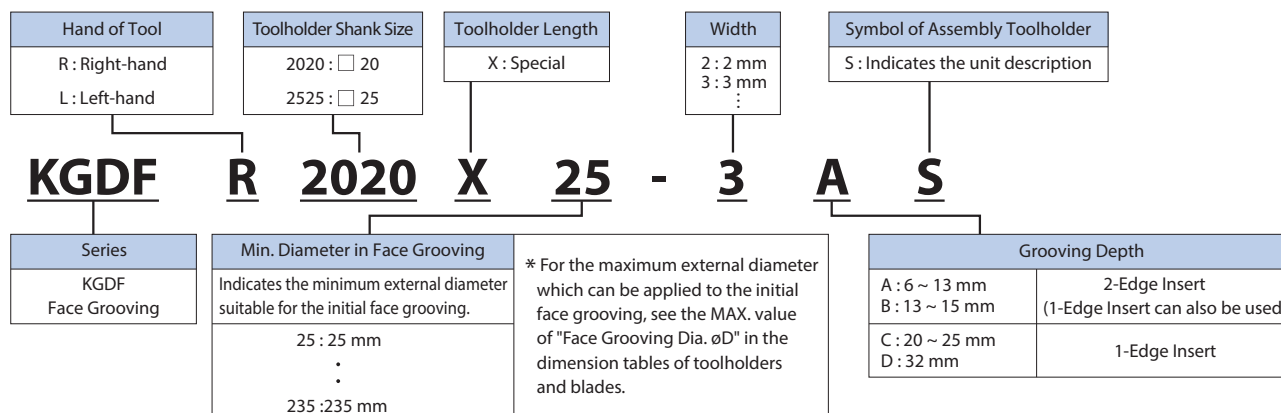

Face Grooving Dia. (ϕD)

Face grooving diameter (ϕD) is the suitable value for the initial grooving on the unprocessed workpiece (See Fig.1).

Then, you can widen it up to the center towards the inside (excluding the models listed in the below table) and towards the outside according to machine limits.

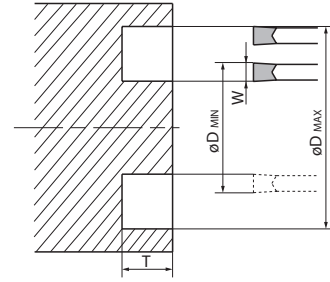
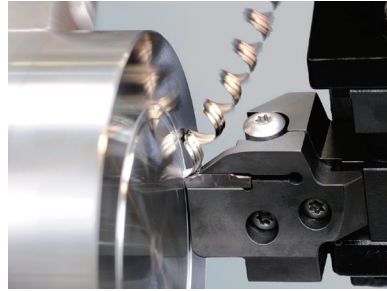
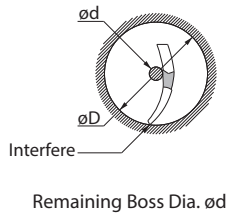

Fig.1

Limit of Turning toward Center

Turning towards the Center causes the toolholder to interfere with the groove wall depending on the initial cut's diameter.

Description	ϕD			
	25	26	27	28 and over
KGDF ^{R/L} 2020X25-3AS 2525X25-3AS	4	2	0	0 (No remaining Boss)
KGDF ^{R/L} 2020X25-4AS 2525X25-4AS	6	3	0	
KGDF ^{R/L} 2020X25-5AS 2525X25-5AS	7	4	1	
KGDF ^{R/L} 2020X25-6AS 2525X25-6AS	9	4	1	



e.g.) If a groove of external diameter $\phi 25$ mm is created using KGDFR2020X25-3AS and turning is made toward the inside, a $\phi 4$ mm portion will be left in middle due to interference of toolholder.

Face Grooving Blade Assembly Identification System

Hand of Tool	Width	Blade Symbol
R : Right-hand L : Left-hand	2 : 2 mm 5 : 5 mm 3 : 3 mm 6 : 6 mm 4 : 4 mm	C : Applicable to toolholder with suffix "-C"

Series	Min. Diameter in Face Grooving	Grooving Depth
KGDF Face Grooving	Indicates the minimum external diameter suitable for the initial face grooving. 25 : 25 mm ⋮ 235 : 235 mm	A : 13 mm 2-Edge Insert B : 15 mm (1-Edge Insert can also be used) C : 20 mm ~ 25 mm 1-Edge Insert D : 32 mm

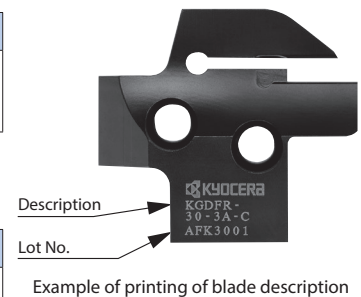

Example of printing of blade description

Face Grooving Blade

Blade Dimensions

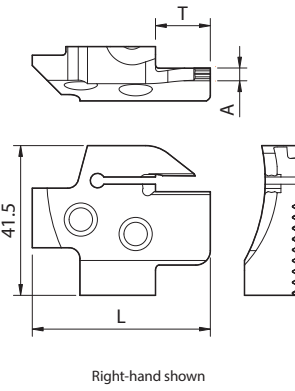
Shape	Blade Description	Stock		Dimensions(mm)			Face Grooving Dia. ϕD (mm)		Insert Width (mm) W	Applicable Inserts ➔ P18	Description of Toolholder ➔ P10		
		R	L	L	T	A	MIN.	MAX.					
	KGDFR	-25-2A-C	●	—	44.35	6	1.5	25	30	2	GDFM 2020N-020GM		
		-30-2A-C	●	—				30	35				
		-35-2A-C	●	—				35	45				
		-45-2A-C	●	—				45	60				
		-60-2A-C	●	—				60	80				
		-80-2A-C	●	—				80	100				
		-100-2A-C	●	—	100	130							
		-25-2B-C	●	—	47.35	13	25	30					
		-30-2B-C	●	—	49.35	15	30	35					
		-35-2B-C	●	—			35	45					
		-45-2B-C	●	—			45	60					
		-60-2B-C	●	—			60	80					
		-80-2B-C	●	—			80	100					
		-100-2B-C	●	—			100	130					
	KGDF ^{R/L}	-25-3A-C	●	●	47.35	13	2	25	30	3	GDFM 3020N-030GM GDFM 3020N-030DM GDFMS 3020N-030DM GDFM3020N-150R-CM		
		-30-3A-C	●	●	49.35	15		30	40				
		-40-3A-C	●	●				40	50				
		-50-3B-C	●	●	56.35	22		50	65				
		-65-3B-C	●	●				65	85				
		-85-3B-C	●	●				85	110				
		-110-3B-C	●	●				110	145				
		-50-3C-C	●	●	59.35	25		50	65				
		-65-3C-C	●	●				65	85				
		-85-3C-C	●	●				85	110				
	-110-3C-C	●	●	110			145						
	KGDF ^{R/L}	-25-4A-C	●	●	47.35	13	3	25	35	4	GDFM 4020N-040GM GDFM 4020N-040GH GDFM 4020N-040DM GDFMS 4020N-040DM GDFM4020N-200R-CM		
		-35-4B-C	●	●	49.35	15		35	50				
		-50-4B-C	●	●				50	70				
		-70-4B-C	●	●				70	100				
		-100-4B-C	●	●				100	150				
		-150-4B-C	●	●				150	220				
		-220-4B-C	●	●				220	∞				
		-35-4C-C	●	●	59.35	25		35	50				
		-50-4C-C	●	●				50	70				
		-70-4C-C	●	●				70	100				
		-100-4C-C	●	●				100	150				
		-150-4C-C	●	●				150	220				
		-220-4C-C	●	●				220	∞				
		KGDF ^{R/L}	-25-5B-C	●				●	49.35			15	4
	-35-5B-C		●	●			35	50					
	-50-5B-C		●	●	50	75							
	-75-5B-C		●	●	75	115							
	-115-5B-C		●	●	115	180							
	-180-5B-C		●	●	180	235							
	-235-5B-C		●	●	235	∞							
	-25-5C-C		●	●	54.35	20	25	35					
	-35-5C-C		●	●	59.35	25	35	50					
	-50-5C-C		●	●			50	75					
	-75-5C-C	●	●	75			115						
	-115-5C-C	●	●	115			180						
	-180-5C-C	●	●	66.35	32	180	235						
	-235-5C-C	●	●			235	∞						
	-75-5D-C	●	●			75	115						
	-115-5D-C	●	●			115	180						
	-180-5D-C	●	●	66.35	32	180	235						
	-235-5D-C	●	●			235	∞						
	KGDF ^{R/L}	-25-6B-C	●	●	49.35	15	5	25	35	6	GDFM 6020N-040GM GDFM 6020N-080GM GDFM 6020N-040GH GDFM 6020N-080GH GDFM 6020N-040DM GDFMS 6020N-040DM GDFM6020N-300R-CM		
		-35-6B-C	●	●				35	50				
		-50-6B-C	●	●				50	75				
		-75-6B-C	●	●				75	115				
		-115-6B-C	●	●				115	180				
		-180-6B-C	●	●				180	235				
		-235-6B-C	●	●	235	∞							
		-25-6C-C	●	●	54.35	20		25	35				
		-35-6C-C	●	●	59.35	25		35	50				
		-50-6C-C	●	●				50	75				
		-75-6C-C	●	●				75	115				
		-115-6C-C	●	●				115	180				
		-180-6C-C	●	●	66.35	32		180	235				
		-235-6C-C	●	●				235	∞				
		-75-6D-C	●	●				75	115				
		-115-6D-C	●	●				115	180				
	-180-6D-C	●	●	66.35	32	180	235						
	-235-6D-C	●	●			235	∞						

● : Standard Stock

KGDF-Z (Face Grooving / Integral Type)

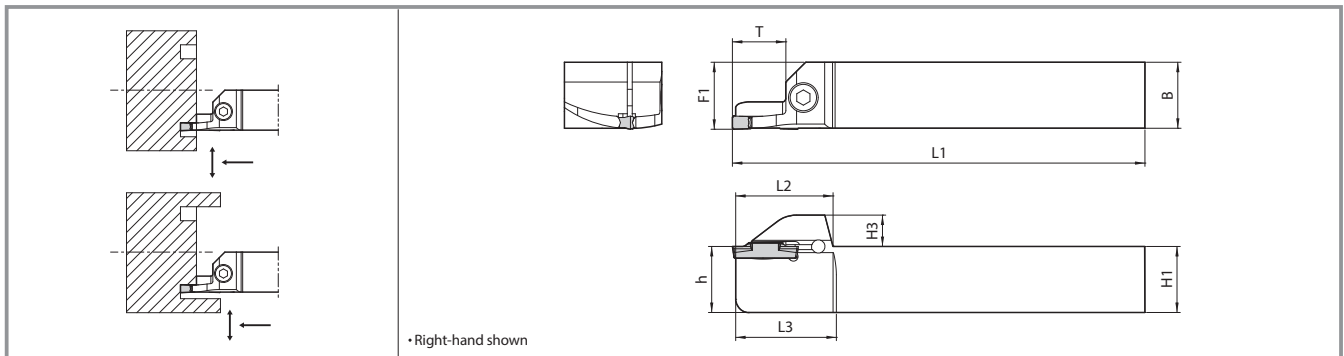



Toolholder Dimensions

Insert Width W (mm)	Shank Size (mm)	Max. Grooving Depth (mm)	Face Grooving Dia. øD (mm)		Description	Stock		Dimensions(mm)								
			MIN.	MAX.		R	L	H1=h	H3	B	L1	L2	L3	F1	T	
3	□20	15	50	65	KGDF ^{R/L}	2020K50-3B-Z	●	●	20	9.5	20	125	30.5	31	20.3	15
			65	85		2020K65-3B-Z	●	●								
			85	110		2020K85-3B-Z	●	●								
			110	145		2020K110-3B-Z	●	●								
	□25		50	65	KGDF ^{R/L}	2525M50-3B-Z	●	●	25	25	150	30.5	31	25.3	15	
			65	85		2525M65-3B-Z	●	●								
			85	110		2525M85-3B-Z	●	●								
			110	145		2525M110-3B-Z	●	●								
4	□20	15	50	70	KGDF ^{R/L}	2020K50-4B-Z	●	●	20	9.5	20	125	30.5	31	20.3	15
			70	100		2020K70-4B-Z	●	●								
			100	150		2020K100-4B-Z	●	●								
			50	70		KGDF ^{R/L}	2525M50-4B-Z	●								
	70		100	2525M70-4B-Z	●		●									
	100		150	2525M100-4B-Z	●		●									
	50		75	KGDF ^{R/L}	2020K50-5B-Z		●	●	20	9.5	20	125	30.5	31	20.3	15
	75		115		2020K75-5B-Z	●	●									
115	180	2020K115-5B-Z	●		●											
50	75	KGDF ^{R/L}	2525M50-5B-Z		●	●	25	25								
75	115		2525M75-5B-Z	●	●											
115	180		2525M115-5B-Z	●	●											

● : Standard Stock
Applicable Inserts → P18

Spare Parts

Description	Spare Parts	
	Clamp Bolt	Wrench
KGDF ^{R/L} ...-Z	 HH5 X 16	 LW-4

Toolholders Identification System

Series	Hand of Tool	Shank Size	Toolholder Length	Min. Face Grooving Dia.	Insert Width	Grooving Depth	Toolholder Type
KGDF Face Grooving	R : Right-hand L : Left-hand	2020 : □ 20 mm 2525 : □ 25 mm	K : 125 mm M : 150 mm	50 : 50 mm : 115 : 115 mm	3 : 3 mm 4 : 4 mm 5 : 5 mm	B : 15 mm	Z : Integral Type

KGDF (Face Grooving / 90° SwitchBlade Type)

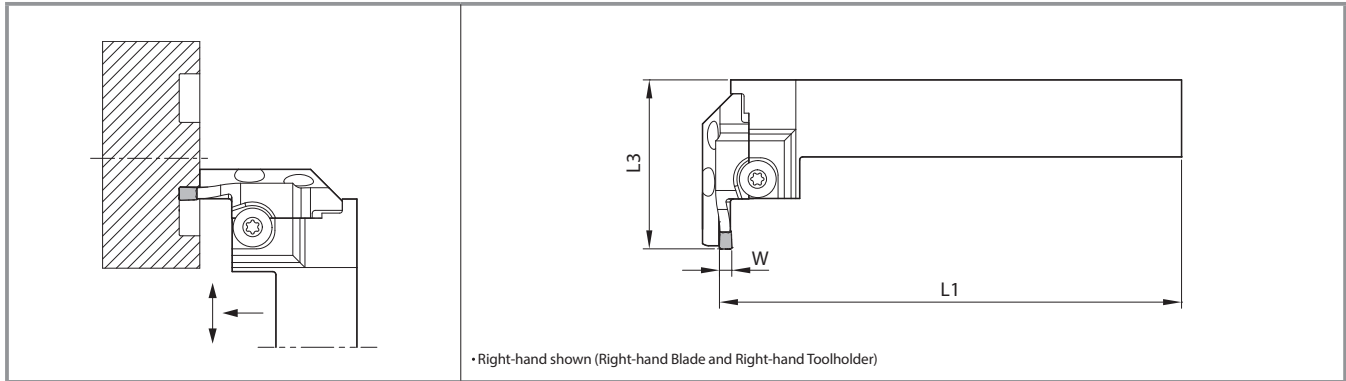

Toolholder Dimensions

Shank Angle	Insert Width W (mm)	Shank Size (mm)	Max. Grooving Depth (mm)	Face Grooving Dia. øD (mm)		Blade Description → P25	Toolholder Description → P10	Dimensions (mm)							
				MIN.	MAX.			L1	L3						
90°	2	□ 20	6	25	30	KGDFR -25-2A-C	KGDSR2020-C	125	49.7						
				30	35					-30-2A-C					
				35	45					-35-2A-C					
				45	60					-45-2A-C					
				60	80					-60-2A-C					
				80	100					-80-2A-C					
			100	130	-100-2A-C										
			13	25	KGDFR -25-2B-C	KGDSR2020-C				125	52.7				
			30	35								-30-2B-C			
			35	45								-35-2B-C			
			45	60								-45-2B-C			
			60	80								-60-2B-C			
		80	100	-80-2B-C											
		100	130	-100-2B-C											
		15	25	KGDFR -25-2B-C	KGDSR2020-C		125	54.7							
		30	35						-30-2B-C						
		35	45						-35-2B-C						
		45	60						-45-2B-C						
		60	80						-60-2B-C						
		80	100			-80-2B-C									
		100	130	-100-2B-C											
		15	25	KGDFR -25-2A-C		KGDSR2525-C			150	49.7					
		30	35								-30-2A-C				
		35	45								-35-2A-C				
45	60	-45-2A-C													
60	80	-60-2A-C													
80	100	-80-2A-C													
100	130	-100-2A-C													
13	25	KGDFR -25-2B-C	KGDSR2525-C	150	52.7										
30	35						-30-2B-C								
35	45						-35-2B-C								
45	60						-45-2B-C								
60	80						-60-2B-C								
80	100					-80-2B-C									
100	130	-100-2B-C													
15	25	KGDFR -25-2B-C				KGDSR2525-C	150	54.7							
30	35								-30-2B-C						
35	45								-35-2B-C						
45	60								-45-2B-C						
60	80								-60-2B-C						
80	100		-80-2B-C												
100	130	-100-2B-C													
90°	3	□ 20	13	25	30				KGDF R/L -25-3A-C	KGDS R/L2020-C	125	52.7			
				30	40								-30-3A-C		
				40	50								-40-3A-C		
				50	65								-50-3B-C		
				65	85								-65-3B-C		
				85	110	-85-3B-C									
			110	145	-110-3B-C										
			15	50	KGDF R/L -25-3A-C	KGDS R/L2020-C	125	54.7							
			65	85					-65-3B-C						
			85	110					-85-3B-C						
			110	145					-110-3B-C						
			22	50					-50-3C-C						
		65	85	-65-3C-C											
		25	85	KGDF R/L -25-3A-C	KGDS R/L2525-C				150	61.7					
		110	145								-110-3C-C				
		13	25								KGDF R/L -25-3A-C	KGDS R/L2525-C	150	52.7	
		30	40												-30-3A-C
		40	50												-40-3A-C
		50	65												-50-3B-C
		65	85	-65-3B-C											
		85	110	-85-3B-C											
		110	145	-110-3B-C											
		15	65	KGDF R/L -25-3A-C		KGDS R/L2525-C	150	54.7							
		85	110								-85-3B-C				
110	145	-110-3B-C													
22	50	-50-3C-C													
65	85	-65-3C-C													
25	85	KGDF R/L -25-3A-C	KGDS R/L2525-C		150				61.7						
110	145			-110-3C-C											

Applicable Inserts → P18

Shank Angle	Insert Width W (mm)	Shank Size (mm)	Max. Grooving Depth (mm)	Face Grooving Dia. øD (mm)		Blade Description → P25	Toolholder Description → P10	Dimensions (mm)				
				MIN.	MAX.			L1	L3			
90°	4	□ 20	13	25	35	KGDF R/L -25-4A-C	KGDS R/L2020-C	125	52.7			
				35	50					-35-4B-C		
				50	70					-50-4B-C		
				70	100					-70-4B-C		
				100	150					-100-4B-C		
				150	220					-150-4B-C		
			220	∞	-220-4B-C							
			15	35	KGDF R/L -25-4A-C	KGDS R/L2020-C				125	54.7	
			50	70								-50-4B-C
			70	100								-70-4B-C
			100	150								-100-4B-C
			150	220								-150-4B-C
		220	∞	-220-4B-C								
		25	35	KGDF R/L -25-4A-C	KGDS R/L2020-C		125	64.7				
		50	70						-50-4B-C			
		70	100						-70-4B-C			
		100	150						-100-4B-C			
		150	220						-150-4B-C			
		220	∞						-220-4B-C			
		15	25	KGDF R/L -25-4A-C		KGDS R/L2525-C			150	52.7		
		35	50								-35-4B-C	
		50	70								-50-4B-C	
		70	100								-70-4B-C	
		100	150								-100-4B-C	
150	220	-150-4B-C										
220	∞	-220-4B-C										
25	35	KGDF R/L -25-4A-C	KGDS R/L2525-C	150	64.7							
50	70						-50-4B-C					
70	100						-70-4B-C					
100	150						-100-4B-C					
150	220						-150-4B-C					
220	∞					-220-4B-C						

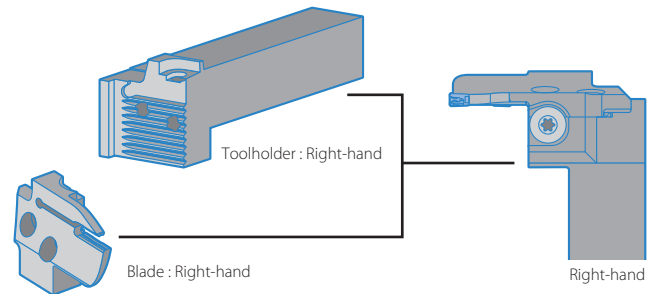

- KGDF 90° SwitchBlade type is not available as unit (toolholder + blade). Blade and toolholder are available to assemble when purchasing individually.
- Right-hand Blade for Right-hand Toolholder, Left-hand Blade for Left-hand Toolholder.
- Insert clamp bolt (BH6x10TR), Blade fixing bolt (SB-60120TR) and Wrench (LTW-25) come with toolholder.

Applicable Inserts → P18

KGDF (Face Grooving / 90° SwitchBlade Type)

Toolholder Dimensions

Shank Angle	Insert Width W (mm)	Shank Size (mm)	Max. Grooving Depth (mm)	Face Grooving Dia. øD (mm)		Blade Description → P25	Toolholder Description → P10	Dimensions (mm)	
				MIN.	MAX.			L1	L3
90°	5	□ 20	15	25	35	KGDF ^{R/L} -25-5B-C	KGDS ^{R/L} 2020-C	125	54.7
				35	50	-35-5B-C			
				50	75	-50-5B-C			
				75	115	-75-5B-C			
				115	180	-115-5B-C			
				180	235	-180-5B-C			
			235	∞	-235-5B-C				
			20	25	35	-25-5C-C		59.7	
			35	50	-35-5C-C				
		50	75	-50-5C-C					
		75	115	-75-5C-C					
		115	180	-115-5C-C					
		180	235	-180-5C-C					
		235	∞	-235-5C-C					
		32	75	115	-75-5D-C	71.7			
		115	180	-115-5D-C					
		180	235	-180-5D-C					
		235	∞	-235-5D-C					
	5	□ 25	15	25	35	KGDF ^{R/L} -25-5B-C	KGDS ^{R/L} 2525-C	150	54.7
				35	50	-35-5B-C			
				50	75	-50-5B-C			
				75	115	-75-5B-C			
				115	180	-115-5B-C			
				180	235	-180-5B-C			
			235	∞	-235-5B-C				
			20	25	35	-25-5C-C		59.7	
			35	50	-35-5C-C				
			50	75	-50-5C-C				
			75	115	-75-5C-C				
			115	180	-115-5C-C				
			180	235	-180-5C-C				
			235	∞	-235-5C-C				
			32	75	115	-75-5D-C			71.7
			115	180	-115-5D-C				
			180	235	-180-5D-C				
			235	∞	-235-5D-C				

Applicable Inserts → P18

Shank Angle	Insert Width W (mm)	Shank Size (mm)	Max. Grooving Depth (mm)	Face Grooving Dia. øD (mm)		Blade Description → P25	Toolholder Description → P10	Dimensions (mm)	
				MIN.	MAX.			L1	L3
90°	6	□ 20	15	25	35	KGDF ^{R/L} -25-6B-C	KGDS ^{R/L} 2020-C	125	54.7
				35	50	-35-6B-C			
				50	75	-50-6B-C			
				75	115	-75-6B-C			
				115	180	-115-6B-C			
				180	235	-180-6B-C			
			235	∞	-235-6B-C				
			20	25	35	-25-6C-C		59.7	
			35	50	-35-6C-C				
		50	75	-50-6C-C					
		75	115	-75-6C-C					
		115	180	-115-6C-C					
		180	235	-180-6C-C					
		235	∞	-235-6C-C					
		32	75	115	-75-6D-C	71.7			
		115	180	-115-6D-C					
		180	235	-180-6D-C					
		235	∞	-235-6D-C					
	6	□ 25	15	25	35	KGDF ^{R/L} -25-6B-C	KGDS ^{R/L} 2525-C	150	54.7
				35	50	-35-6B-C			
				50	75	-50-6B-C			
				75	115	-75-6B-C			
				115	180	-115-6B-C			
				180	235	-180-6B-C			
			235	∞	-235-6B-C				
			20	25	35	-25-6C-C		59.7	
			35	50	-35-6C-C				
			50	75	-50-6C-C				
			75	115	-75-6C-C				
			115	180	-115-6C-C				
			180	235	-180-6C-C				
			235	∞	-235-6C-C				
			32	75	115	-75-6D-C			71.7
			115	180	-115-6D-C				
			180	235	-180-6D-C				
			235	∞	-235-6D-C				

Applicable Inserts → P18

Recommended Cutting Conditions (Face Grooving) ★1st Recommendation ☆2nd Recommendation

Workpiece	Recommended Insert Grade (Vc : m/min)				Notes
	Cermet		MEGACOAT		
	TN620	TN90	PR1225	PR1215	
Carbon Steel	☆ 60 – 200	☆ 80 – 200	★ 60 – 160	☆ 80 – 160	Coolant
Alloy Steel	☆ 60 – 160	☆ 70 – 160	★ 60 – 150	☆ 60 – 150	
Stainless Steel	—	—	★ 50 – 120	☆ 50 – 120	
Cast Iron	—	—	—	★ 80 – 160	

Recommended Cutting Conditions (Feed Rate / D.O.C.)

(Workpiece : S50C)

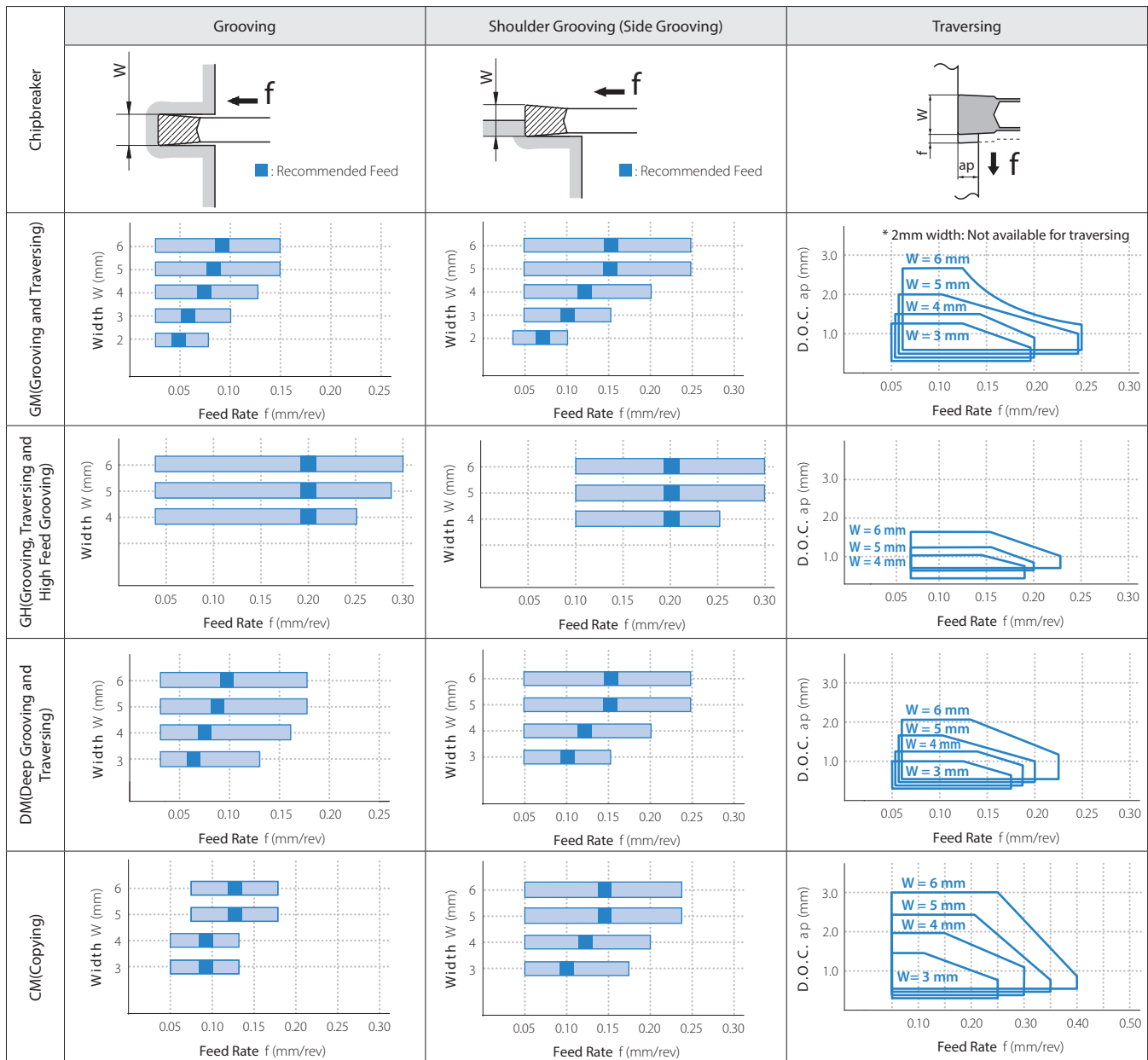

When shouldering,

- If D.O.C. is set smaller, set feed higher.
- If D.O.C. is set larger, set feed lower.

1) The above values reflect a T dimension that is 15mm or less.

When T dimension is over 17mm, set the values for traversing to less than 90% of recommended cutting conditions above.

Guide for Face Grooving

1 Toolholder Selection

Check the range of applicable "face grooving diameter" as well as the groove width and depth.

2 Cutting conditions (Feed rate : f)

When machining steel, set the feed rate (f) so that chips are created in a helical form when plunging.

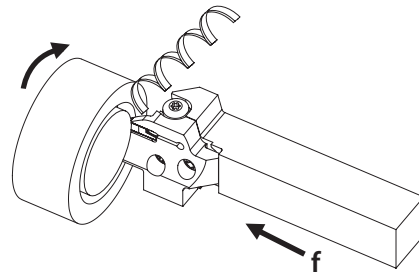

3 Expanding Groove Width (Plunging and Traversing)

Start machining from the outside and then proceed to the inside. Chip control will be better in this way.

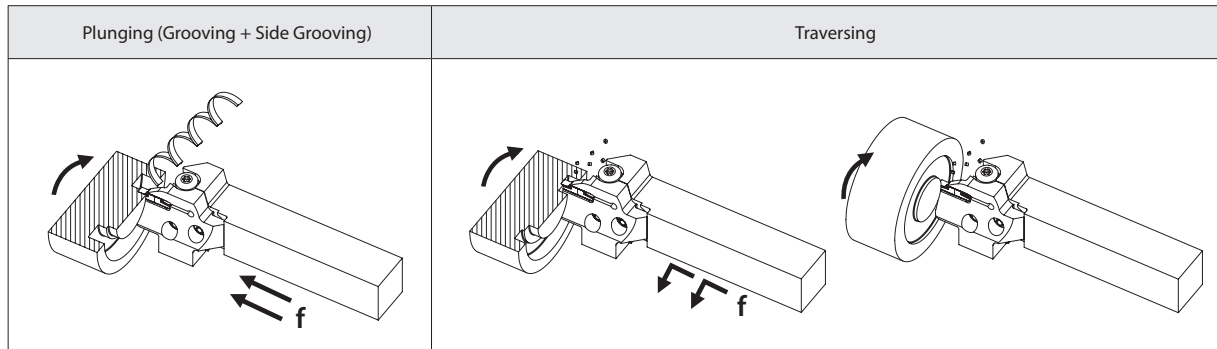

4 Guide for Traversing

A. When the cutting amount (D.O.C.) is over 0.5mm

- (1) Plunging
- (2) Return the cutting by 0.1 mm
(Failure to pull the tool back before traverse cutting will result in an unbalanced load applied on only one side of the cutting edge.)
- (3) Perform traversing (see Fig.1)

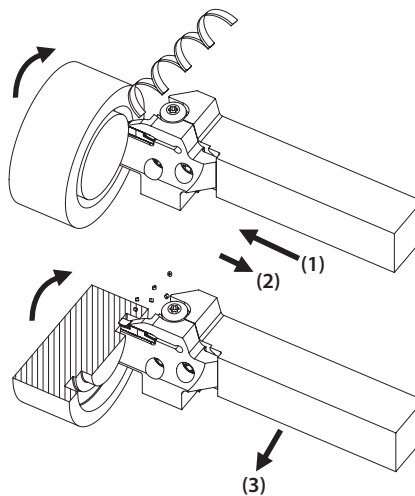

Fig.1

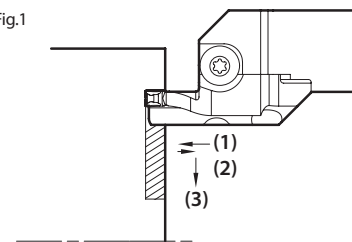
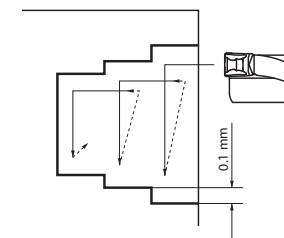

Fig.2



- When widening the face groove width (see Fig.2) Apply the "Step Turning". Then perform finishing.

B. When the cutting amount (D.O.C.) is under 0.5mm

- (1) Plunging
- (2) Perform traversing
Machining without interruption is possible. (see Fig.3)

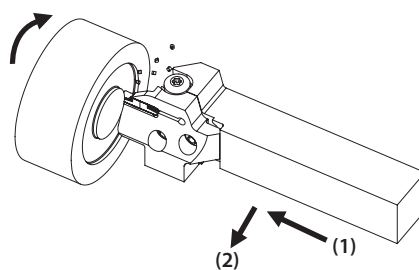
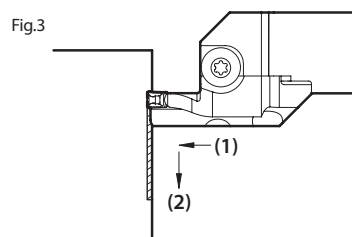

Fig.3



Case Studies

Gear SCr420H (Grooving)

Vc = 113 ~ 164 m/min
 f = 0.06 mm/rev
 Wet
 GDM4020N-040GM (PR1225)
 KGDL2525X-3T10S

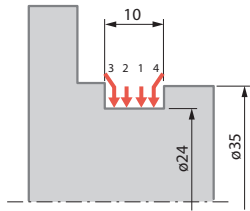

Tool Life

GM Chipbreaker
 (PR1225)

1500 pcs/edge

6 times

Competitor C
 (PVD Coated Carbide)

250 pcs/edge

KGd-type and GM chipbreaker (PR1225) improved tool life to 6 times of Competitor C. No burned chips and good chip control.



(User evaluation)

Sleeve S45CF (Cut-off)

Vc = 103 m/min
 f = 0.12 mm/rev
 Wet
 GDM3020N-025PM (PR1225)
 KGDL2525X-3T20S

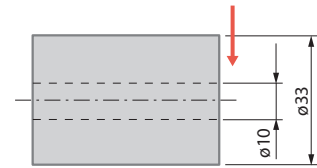

Tool Life

PM Chipbreaker
 (PR1225)

250 pcs/edge, capable of further machining

Competitor D
 (PVD Coated Carbide)

250 pcs/edge, with chipping

KGd-type and PM chipbreaker (PR1225) showed good edge condition after machining same number of workpieces as Competitor D. Available for further machining. (Comp. D caused chipping)

(User evaluation)

Ball Stud SCM435 (Copying)

Vc = 100 ~ 160 m/min
 ap = 0.3 mm
 f = 0.15 ~ 0.25 mm/rev
 Wet
 GDM3020N-150R-CM (PR1225)
 KGDR2020X-3T10S

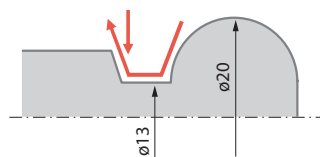

Tool Life

CM Chipbreaker
 (PR1225)

800 pcs/edge

2 times

Conventional A

400 pcs/edge

Resolve issues such as chip-bite and tangled chips due to its superior chip evacuation performance
 ⇒ Resolve brakage of edge caused by chips.
 Doubled tool life by reducing damage on the edge.

(User evaluation)

Piston SCM435H (Face Grooving)

Vc = 150 m/min
 ap = 1, 1.8 mm (Traversing)
 f = 0.05 mm/rev (Grooving)
 0.1, 0.15 mm/rev (Traversing)
 Wet
 GDFM4020N-040GM (PR1225)
 KGDFL2525X50-4CS

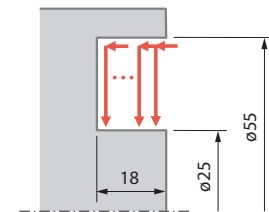

Tool Life

GM Chipbreaker
 (PR1225)

40 pcs/edge, capable of further machining

Conventional B

40 pcs/edge

KGDF+GM chipbreaker improved chip evacuation compared to Conventional B. (Resolved frequent brakage of toolholder.)
 Smaller wear on the edge provided by MEGACOAT make the tool life longer. (Lower running cost by longer tool life)

(User evaluation)